

GENERAL INFORMATION

1.1 SCOPE OF MANUAL

This manual contains operating and maintenance information on the Multiplier Module (AXB), manufactured by MOORE INDUSTRIES INC., Sepulveda, California. The manual consists of six sections as follows:

Section 1, General Information, introduces the equipment function and describes the equipment physical appearance, the equipment specifications, and options available for the unit. The introduction also provides information on the use and description of the MOORE model numbering system.

Section 2, Calibration, provides all the information necessary to calibrate the unit before installation. This section contains a list of the tools necessary for calibrating the equipment; and illustrates the test setups essential to perform that task. The section also lists the various procedures required for calibration of the units in any configuration.

Section 3, Installation and Operation, supplies all the information needed to install and operate the equipment. The section contains figures that specify the installation requirements for the units, and text that informs the user on recommended wiring practices for the equipment as well as defines the electrical connections for each unit regardless of physical modifications. A brief outline of periodic observations required during the equipment operation is also included here.

Section 4, Theory of Operation, gives the maintenance personnel a detailed explanation of the internal function of the unit. The circuit theory is based on a block diagram that shows the functional elements of the unit. Each element operation is then described, first in relation to the other element, then independently where its major components' use and purpose are described.

Section 5, Maintenance, offers complete disassembly procedures for all unit configurations available. Troubleshooting information is also provided in this section as well as component replacement techniques to aid the technician in the repair of the equipment.

Section 6, Unit Documentation, acquaints the user with the MOORE IND. computerized parts listing and identification system. The section also provides a recommended spare parts list. All schematics and parts assembly drawings referred to by the text are located in the back of Section 6.

1.2 EQUIPMENT DESCRIPTION

The Multiplier Module (AXB) is used in process control systems to perform the computation

$$\% \text{ Output} = \%A_{\text{Input}} \times \%B_{\text{Input}}$$

Percentages of two process inputs (A and B) are multiplied to provide a percent current or voltage output as the product. Applications of this module include processes in which mass flow, true watts, BTU, or any other quantity in which a product is involved must be computed.

1.3 PHYSICAL DESCRIPTION

The standard unit consists of a single printed-circuit board (PC1) on which most electronic components are mounted. AC powered units use an additional board: (PC2) mounted on (PC1). This board provides the power regulation circuits. When units are DC powered an additional board is mounted on PC1. This board holds the DC to AC inverter circuits.

The boards are enclosed in a protective housing, and the entire assembly may be installed in a number of ways. Specific details about each unit is outlined in this section, while the following paragraphs outline the physical differences of



Standard (STD) Unit

each option available for the units. Electrical connections information are given in Section 3, Installation and Operation.

1.3.1 Conduit Plate Option (CP) Description

This option consists of an extension of the standard bracket lower mounting flange. The additional surface is cut with two mounting holes to accommodate 1/2-inch electrical conduit. This option is illustrated in the next section outline and dimension drawings.

1.3.2 Angle Bracket (AB) Option Description

This option consists of two angle brackets, one on the top and the other on the bottom of the unit.

These brackets are used to mount the unit in applications where the standard U-bracket will not apply. The brackets are provided with two #10 screw clearance holes each, for ease of mounting.



Unit with Angle Bracket (AB) Option

1.3.3 NEMA Boxes Options Description

Units equipped with angle brackets (AB) option may be enclosed in NEMA boxes to ensure protection against harsh environments that may be damaging to the unit. Four configurations are available for this purpose.

Oil Tight (OT) NEMA Box Option. This enclosure consists of a NEMA12 box construction, with two cover-holding screw clamps, mounted opposite to the hinged side of the cover (right side). These enclosures are oil and dust tight only. Conduit holes, fittings, or knockouts are not provided on these boxes. Suggested fittings are "Myer's Scrutite". The units are mounted on a drilled and tapped mounting plate at the back of the box.

Water Tight (WT) NEMA Box Option. This enclosure consists of a NEMA4 box construction equipped with three cover-holding screw clamps, one on each of the three non-hinged sides of the box. These enclosures are watertight, in addition to oil and dust tight. Unit mounting and electrical connections are made in the same manner as the OT option enclosures.

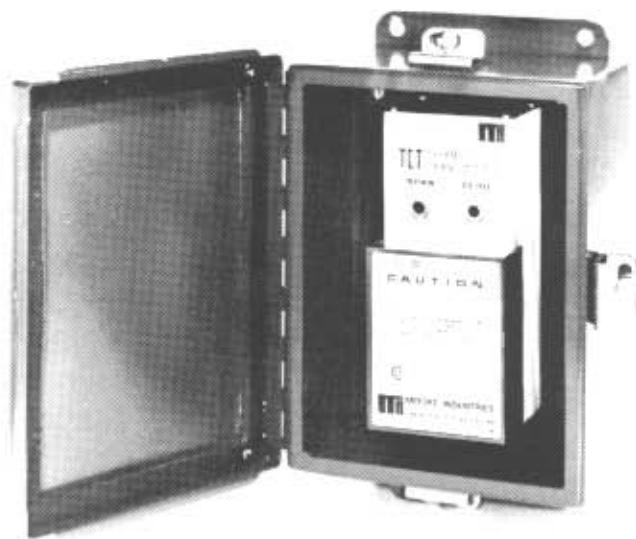

Unit in Water Tight (WT) Enclosure

Fiber Glass (FG) Option Enclosures. This enclosure is molded from pigmented polyester resins, using 302 stainless steel for all exposed hardware. A one-piece neoprene jacket provides additional sealing protection against corrosive environments. Boxes are normally hinged on the long side. The cover is secured by four slot-head screws accessible at the top of the cover and located on each side of the top and bottom cover corners opposite the hinge side. Conduit holes may be cut with a hole punch, and special precautions must be taken with ground connections, since the box material is non-conductive. Refer to Section 3 for wiring information. Units are mounted into the enclosure in the same way as in the OT enclosures.

SECTION 1

GENERAL INFORMATION

General Purpose (GP) Options Enclosures. This enclosure consists of a general purpose steel construction box with knock-outs for various size electrical conduits ($\frac{1}{2}$, $\frac{3}{4}$, or 1 inch). The cover is hinged and spring locked. Units are secured into the enclosure on four studs and four 10-32 nuts. The complete enclosure can be secured through four mounting holes provided on the box back cover.

1.3.4 RAA and RAT Options Description

These options consist of special mounting hardware attached to MOORE units to replace obsolete instrumentation of other manufacture.



Corrosion Resistant Fiber Glass (FG) Enclosure

Replacement Mounting (RAA) Option



Replacement Mounting (RAT) Option

1.3.5 Plug-In (PC) Units Description

The plug-in unit is electrically similar to the standard unit. Unlike the standard unit, no additional PC boards are mounted on the main board. Thus all the unit electronics are mounted on PC1.

The printed circuit board is keyed to identify the unit and ensure proper connection mating. The other end of the main board is fastened to a display panel that allows external access to the various controls for the unit. A removable plastic safety cover protects the printed circuit board and components from normal environmental hazards. When the PC unit is purchased alone, the user must provide a 15 pin connector, such as Viking part No. ZVK155/1-2 or equivalent. Several mounting options are available for the plug-in unit.

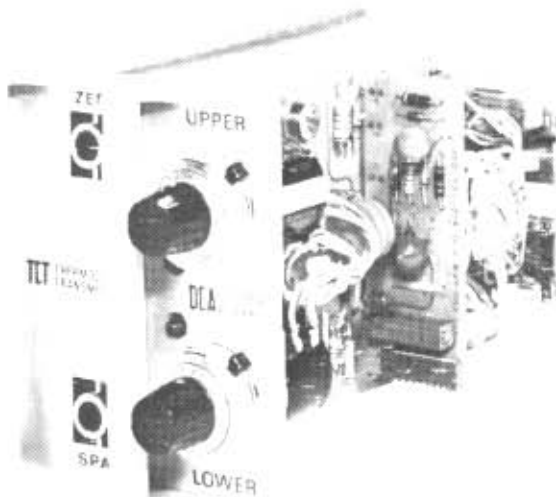

Plug-In (PC) Unit

Rack Mounted (RMR) Card Racks. These enclosures are designed to flush-mount in standard 19 and 24-inch relay racks, respectively. The enclosures are provided with standard EIA hole patterns. Eleven and fifteen position RMR racks are available. These are pre-wired from the module PC connector to the screw-type barrier strip, which are rear-accessed for rack-wiring convenience. All power connections from the PC connectors are bussed together to a separate 3 terminal barrier-strip for external power input. DC power supplies are available. Electrical connections to the card rack are detailed in Section 3, Installation and Operation. Modules are front loaded and a dust cover is provided to minimize the

effects of environmental hazards. Module connectors are keyed to assure that units are plugged into their proper position; keying, however, may be altered in the field if the system configuration changes. Filler cards are available for positions not used by a module.

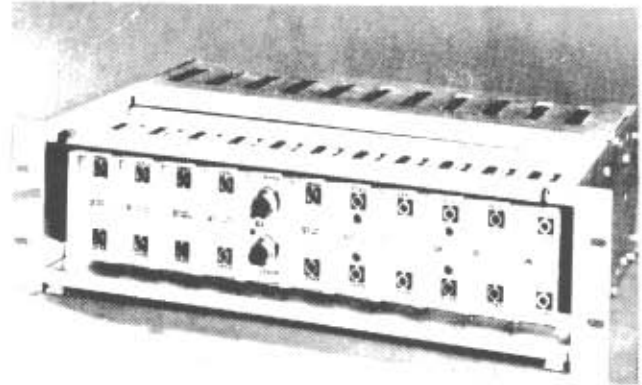

Card Rack Enclosure for Relay Racks (RMR)

Surface Mounted (SMR) Card Rack. These rack enclosures are designed to accommodate as few as five and up to 15 modules. Mounting flanges are located in the rear of the side panel which allows for surface mounting or for NEMA box mounting. These enclosures are electrically identical in construction to the RMR racks. Terminal strips for external connections, however, are front-accessed for wiring convenience whenever the rack is mounted into a NEMA box or against a wall.

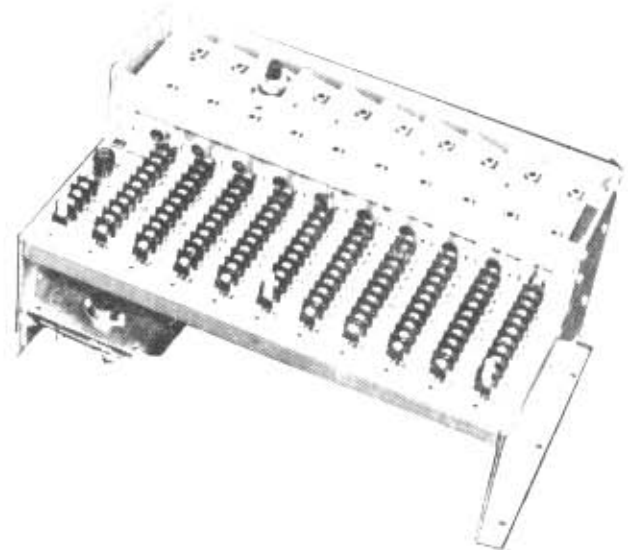

Surface Mounted Card Racks (SMR)

1.3.6 Standard Plug-In Transmitter (PST) Options

The standard plug-in transmitter consists of a standard enclosure as described in paragraph 1.3

SECTION 1

GENERAL INFORMATION

except that connections are not provided on the face of the unit. Instead, the transmitter is attached physically and electrically to a circular interconnect card with plug-in pins, keyed to eliminate errors in connections. The mating connector consists of a bracket-mounted square terminal block. External electrical connections are made to screw terminals located on the periphery of the connector block. A plug-in receptacle arrangement is located in the center of the block to accommodate the keyed interconnect card plug-in pins from the transmitter. The mounting bracket secured to the terminal block is pre-drilled with clearance holes for 10-32 screws. When the transmitter assembly is removed, the terminal block screw connections are easily accessible.

block as with the PST option. Instead, the terminal block is secured flush with the bottom of the housing. Electrical conduit hubs are provided for external electrical wiring through electrical conduits. Several configurations of conduit inputs are available. Refer to Section 3 for detailed description of conduit configurations.

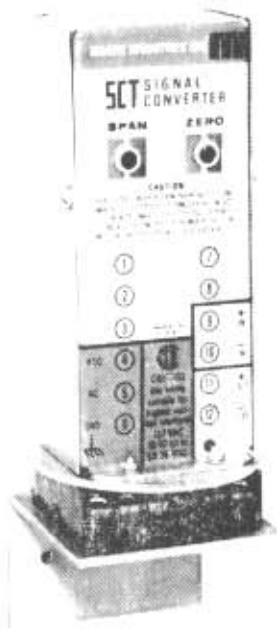

Plug-In Standard Unit (PST)

1.3.7 Explosion Proof (EX) Option

The explosion-proof enclosure option consists of a PST option unit described in paragraph 1.3.6 enclosed into a two-piece cast aluminum alloy enclosure. The two pieces consist of a screw-type cover and a connector housing. When the cover is removed, the PST type unit is easily accessible. With the PST unit unplugged, the terminal block is clearly visible and connections are made with ease. No mounting bracket is used on the terminal

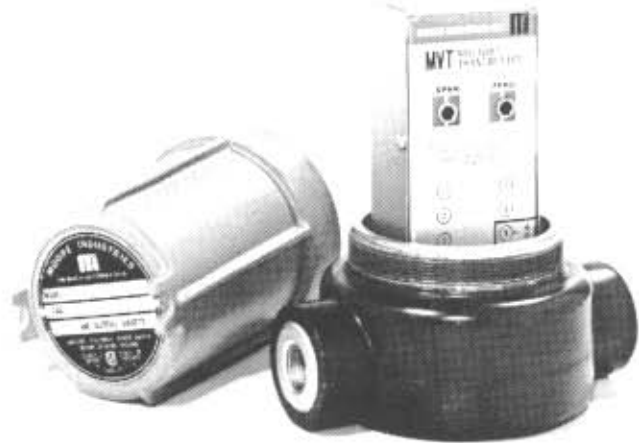

Explosion Proof Housing (EX Shown Only)

1.3.8 Panel Mounted Transmitter (PM) Option

This option is electrically similar to the standard unit of paragraph 1.3, except that the enclosure and terminals locations are different. Instead of the standard enclosure, the printed circuit boards are enclosed in a metal frame equipped with a blank panel. Controls and electrical connections are accessible to the rear of the enclosure by removing a cover. The bottom of the frame is provided with two holes to accommodate 1/2-inch electrical conduit.

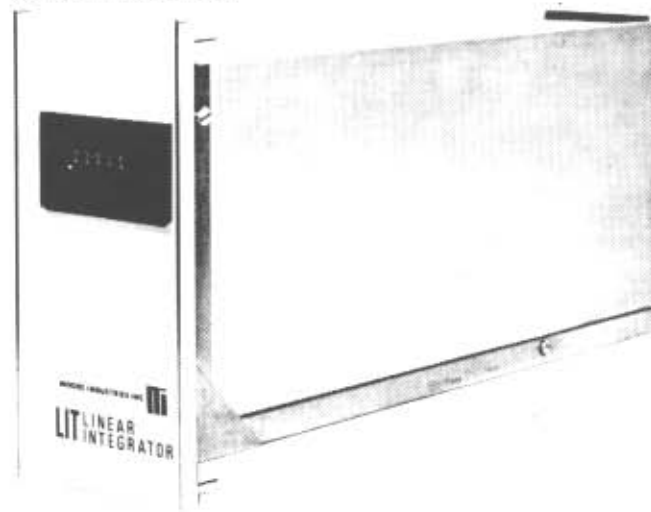

Panel Mounted Unit (PM)

1.4 SPECIFICATIONS

The specifications for the unit are listed in Table 1-1.

1.5 MODEL NUMBER EXPLANATION AND USE

MOORE INDUSTRIES' model numbers describe an instrument's type, functional characteristics, operating parameter, and include option identification. If all accompanying documentation of a unit is missing, the model number may be used to obtain technical information on the unit by following the example of Table 1-2. The model number for standard units, and units with CP and AB options, is located at the upper end of the terminal block stamped on a stainless steel tag. Plug-in units have their model number labeled on the inside of the grip extension to the front panel. PST units have the model number on top of the transmitter case. For explosion-proof units, the model number is stamped on a stainless steel tag on top of the enclosure and on the identification label on the

unit within the enclosure. PM units model numbers are stamped on a stainless steel tag, visible when the rear safety cover is removed. To expose the model number on all NEMA box enclosures, open box and remove safety cover of the unit.

1.6 SERIAL NUMBER USE AND LOCATION

A complete history is kept on every MOORE unit. This information is keyed to the serial number. Whenever service data is required on a unit, it is necessary to provide the factory with a serial number as well as a model number. This identification is usually located with the model number (see paragraph 1.5 for location on equipment) except for plug-in units and explosion proof where the serial number is engraved into the PC board or stamped on a stainless steel tag respectively, and is usually preceded by the letter E.

TABLE 1-1. UNIT SPECIFICATIONS

INPUT:	
Current:	
1-5 mA into 200 ohms nominal	
4-20 mA into 50 ohms nominal	
10-50 mA into 20 ohms nominal	
Voltage:	
0-5V, 1-5V standard	
10 megohms minimum input impedance	
Other voltages available	
FRONT PANEL ADJUSTMENTS:	Adjustable with multi-turn potentiometer
Span:	With full scale input, adjusts output to 100% ±20% of selected output span
Zero:	With minimum input, adjusts output to 0% ±10% of selected output span
A & B Input Zero:	Compensates for input live zero offset for specified zero percent input ±10% of span
OUTPUT:	Operational amplifier feedback current source; output limited to 150% of maximum output range value
Current:	
1-5 mA into 0-4800 ohm load	
4-20 mA into 0-1200 ohm load	
10-50 mA into 0-480 ohm load	
Voltage:	1-5V DC standard into 20K ohms minimum
Other voltages available	
Function:	Output = $K_O (K_A \cdot A + K_B \cdot B)$
Ripple:	10 mV P/P at maximum span and maximum load resistance
Load Effect:	±0.01% of span 0 to maximum load resistance (current output)
PERFORMANCE:	
Calibration Capability:	±0.25% of span (Linearity and Repeatability)
Ambient Temperature:	
Range:	—20°F to +180°F (—29°C to +82°C)
Effect:	±0.01%/°F over above range
Frequency Response:	50 Hz (3-dB point)
Isolation:	Voltage output units have input negative side common to output negative side. Current output models have output negative side elevated above input negative side. Mixed outputs are optionally available. Power input isolation is maintained on both AC and DC powered units.
POWER INPUT:	
24V DC, 45V DC, ±10%	
117V AC, 220V AC, or 240V AC, 50/60 Hz, ±10%	
5 Watts nominal	
Line Voltage Effect:	AC or DC: ±0.005%/1% line change
CERTIFICATION:	Canadian Standards Association
WEIGHT:	Approximately 2 lbs. (908 grams)

TABLE 1-2. MODEL NUMBER EXAMPLES

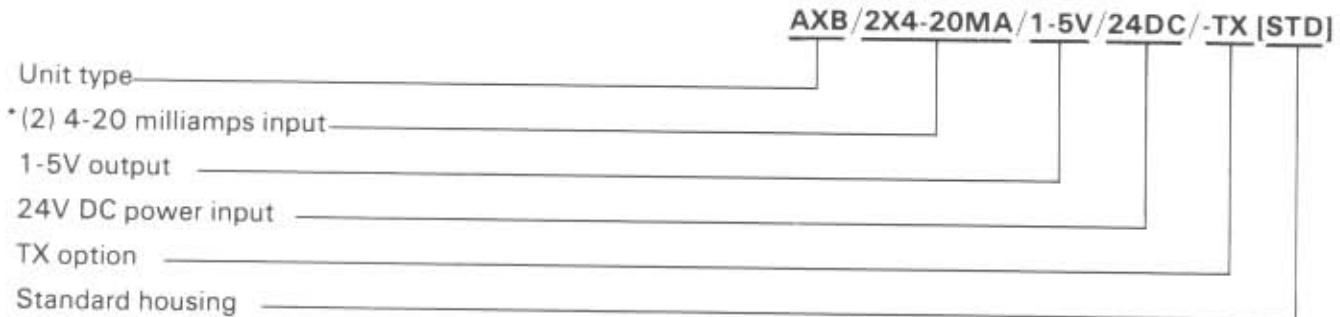

a. Similar Inputs

• **Alternate example:**



b. Dissimilar Inputs

TABLE 1-3. AXB ELECTRICAL OPTIONS

OPTION DESCRIPTION	CODE
Power fuse on plug-in transmitter card (PC housing), 400 mA rating	FU
High-current (20 mA) 1-5V DC output	HI
Internal "K" factor for the A input, factory set	KA
Internal "K" factor for the B input, factory set	KB
Internal "K" factor for the output, factory set	KO
RFI Filter Terminal Assembly — adds Moore Industries patented integral filter terminal assembly which prevents radio frequency energy from entering standard aluminum case	RF
Selectable Output or Input Current	SC
Two-wire Transmitter Excitation — 30V DC @ 25 mA output to a two-wire field transmitter. One 4-20 mA transmitter only. (See ESI-9)	TX

195-701-00A
AXB MULTIPLIER MODULE

CALIBRATION

2.1 GENERAL INFORMATION

This section provides information about unit calibration. Units with standard input and output levels are normally calibrated at the factory. After the unit is unpacked, general operating level checks of units is recommended. Usually these checks, specified in this section under calibration procedures, require little or no adjustments. If units are ordered with factory calibration option (FC), an exact calibration is performed at the factory, and red caps are placed on the controls. Adjustments should not be made in the field on these units unless a new range of input or output signal level is desired. Red caps should not be removed as a precaution against accidental adjustments.

2.2 CONTROLS DESCRIPTION AND LOCATION

The controls consist of ZERO and SPAN adjustments, located on the unit front panel. External controls are multiturn potentiometers that are adjusted with a blade screwdriver.

CAUTION

SCREWDRIVER BLADE MUST NOT BE MORE THAN 0.1 INCH (2.54 mm) WIDE. USE OF A WIDER BLADE MAY PERMANENTLY DAMAGE THE POTENTIOMETER MOUNTING.

This type of potentiometer usually requires 20 turns of the shaft to move the wiper from one end of its range to the other. It is equipped with a slip clutch at either end of its travel to prevent damage if it is turned beyond the wiper stop. Usually a slight change in feel will be noticed when the clutch is slipping. However, if this change is not observed, either end can be reached by turning the shaft 20 turns in the desired direction. Controls are connected, so turning the shaft clockwise increases the quantity or makes it more positive, and turning the shaft counterclockwise has the opposite effect.

2.3 TEST EQUIPMENT AND TOOLS REQUIRED

Test equipment and tools required for calibration of the unit are described in Table 2-1; they are not

TABLE 2-1. TEST EQUIPMENT AND TOOLS REQUIRED

Equipment or Tool	Characteristic	Purpose
Screwdriver (blade)	Blade not wider than 0.1 inch (2.54 mm)	Front panel control adjustment
Adjustable Voltage or Current Source	Must be capable of producing signal ranges defined by INPUT level requirements of purchased unit (see Table 1-1)	Simulate input signal levels
DC Voltmeter	Must be accurate to within $\pm 0.05\%$ or better	Input signal monitoring (voltage inputs only). Output signal monitoring (voltage outputs only)
DC Milliammeter	Must be accurate to within $\pm 0.05\%$ or better	Input signal monitoring (current inputs only). Output signal monitoring (current outputs only)

supplied and must be provided by the customer at the installation or test site.

2.4 TEST EQUIPMENT SETUPS

Off-line calibration for all units require the same test equipment setups regardless of option or physical configuration. The hookup requirements and physical preparations may vary on some units. The following paragraphs define the general test setup and identify the units that require special attention for test preparation and connections.

2.4.1 General Test Equipment Setups

The test equipment setup required for calibration of all units is identical except for connection identification. Figure 2-1 shows the general test setup configuration. Connection nomenclature refer to terminal markings on the standard units with CP, AB, AA/TA, PM, and NEMA boxes mechanical options.

2.4.2 Plug-In Units Test Equipment Setup

Plug-in units equipment test setup is the same as the one shown in Figure 2-1, except that printed circuit board connections are identified in that figure by numbers in parentheses. Connection identification numbers are etched in the component side of the PC board. Plug-in units inserted in

a rack also use the test setup shown in Figure 2-1 with card rack terminal connections identified by numbers in parentheses. These include either the rack mount (RMR) or the surface mounted (SMR).

2.4.3 Explosion-Proof (EX) and PT or PST Option Test Setup

Figure 2-2 shows the general test setup configuration for an explosion-proof enclosure, PT, or PST option. Note that in the explosion proof configuration the protective housing must be opened and the unit removed to expose the connection block. Similarly, units with the PT or PST configuration must be unplugged from the connection block in order to access the connections more effectively. Numbers in parentheses refer to terminal block numbers.

2.5 CALIBRATION

Units are calibrated and checked for proper performance at the factory before they are shipped. However, unless calibration was requested to a specific set of input-output values, the unit performance should be checked by the user before the unit is placed in service. Calibration consists of simulating the operative signal input and adjusting the unit to obtain the specified output.

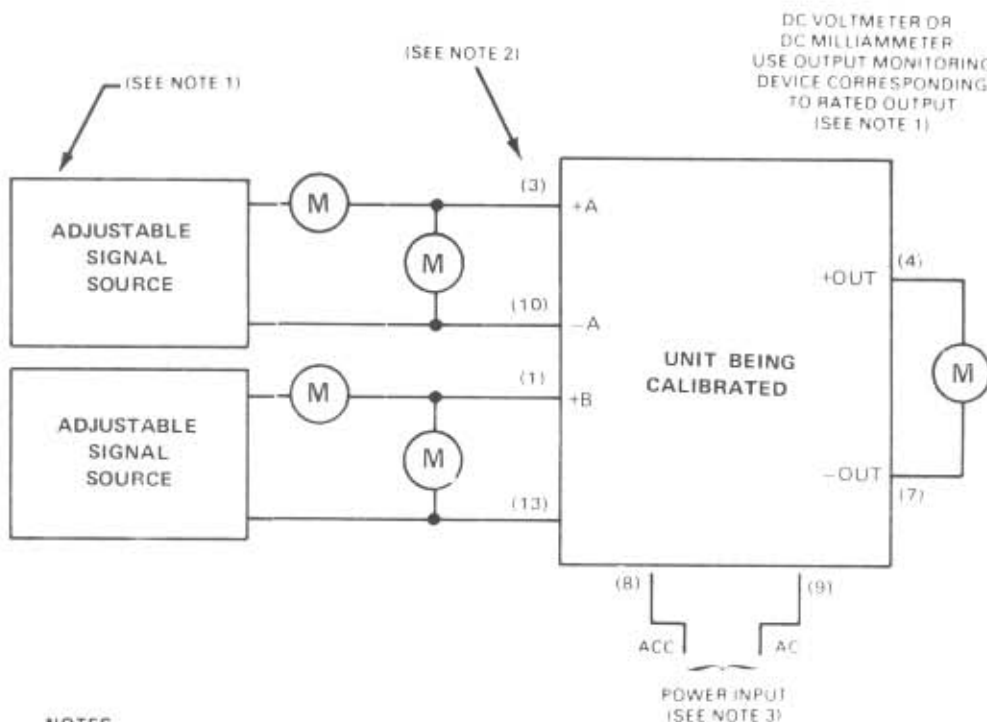

Figure 2-1. Test Equipment Setup For Calibration Of Unit

NOTE

Adjustments should *not* be made in the field on units that are calibrated to values specified in the purchase order. Units that are calibrated at the factory to customer's specifications have protective caps over the SPAN and ZERO potentiometers; do NOT remove these caps.

Two adjustable input signal sources and input monitoring devices and an output monitoring device are required for calibration. Alternatively, MII Test Set PTS-770 may be used to supply and monitor one signal source and for monitoring the output. The monitoring devices (current or voltage) must have an accuracy within $\pm 0.05\%$ or better. To calibrate a unit, proceed as follows:

- a. Refer to Paragraph 5.2 and remove the cover of the unit to gain access to the A and B INPUT ZERO potentiometers.
- b. Connect unit and test equipment as shown in Figure 2-1 or 2-2.
- c. Apply power input to the unit.

NOTE

Refer to Paragraph 1.6 for information on how to use the model number to obtain the specified values of minimum and maximum inputs and outputs.

- d. Adjust both input signal sources A and B to the respective minimum input values specified for the unit (1 mA, 4 mA, 10 mA, 1 VDC, or whatever the specified minimum inputs are for the unit).
- e. Adjust the ZERO potentiometer to obtain 0% output (1 mA, 4 mA, 10 mA, 1 VDC, or whatever the specified 0% output is for the unit).
- f. Adjust both input signal sources A and B to the respective maximum inputs specified for the unit (5 mA, 20 mA, 50 mA, 5 VDC, or

whatever the maximum inputs are for the unit).

- g. Adjust the SPAN potentiometer to obtain 100% output.
- h. Repeat steps (d) and (e).
- i. With input signal source A adjusted to the minimum input value specified for the A input of the unit, vary input signal source B from the minimum to the maximum input value specified for the B input of the unit.
- j. If necessary, adjust the A INPUT ZERO potentiometer so the output does not change when step (i) is repeated.
- k. With input signal source B adjusted to the minimum input value specified for the B input of the unit, vary input signal source A from the minimum to the maximum input value specified for the A input of the unit.
- l. If necessary, adjust the B INPUT ZERO potentiometer so the output does not change when step (k) is repeated.
- m. Repeat steps (d) through (g).
- n. Adjust input signal source A to the maximum input value specified for the unit, and adjust input signal source B to 10% of the span above the minimum value specified for the B input of the unit.
- o. Adjust the ZERO potentiometer for 10% of full scale output.
- p. Adjust signal source B to the maximum input value specified for the B input of the unit.
- q. Adjust the SPAN potentiometer to obtain 100% output.
- r. Repeat steps (n) through (q).
- s. After step (r) has been successfully completed, remove the input signal sources, turn off the power input to the unit, and reinstall the cover onto the unit.

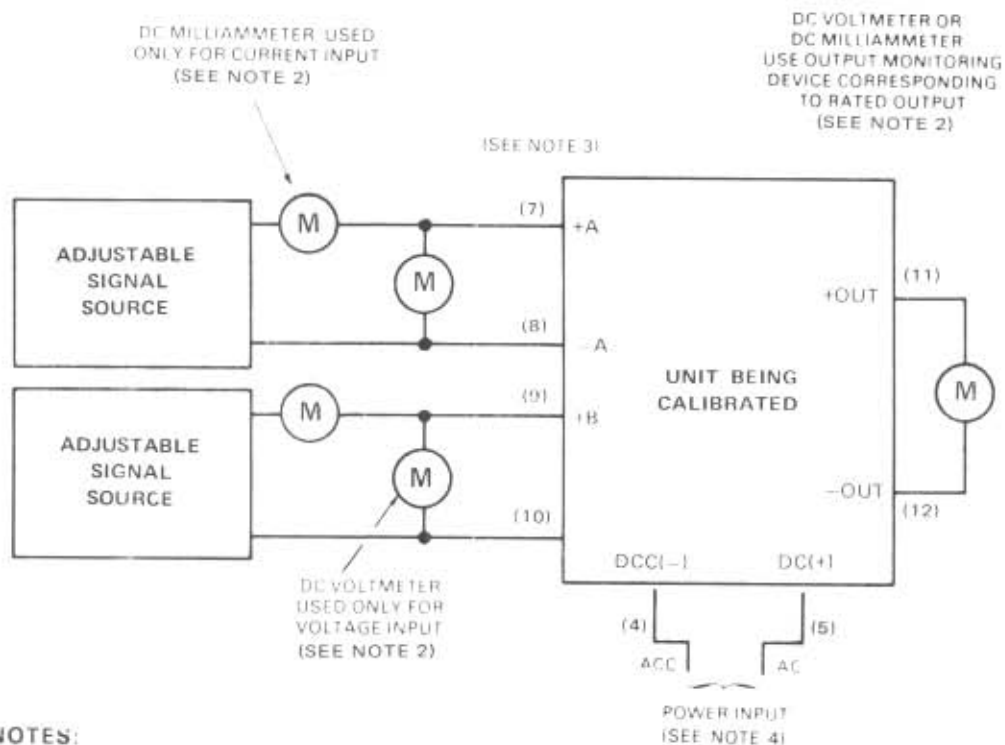

NOTES:

1. Test setup must be locally fabricated. Components not supplied as a part of the purchased unit.
2. Input and output monitoring devices must be accurate to within $\pm 0.05\%$ or better.
3. Numbers in () refer to terminal block connector (see Figure 3.12).
4. Either AC power or DC power is supplied, but not both.
5. Calibration resistor terminals used for RC option only.

Figure 2-2. Test Equipment Setup For Calibration of Explosion Proof and PT or PST Unit

INSTALLATION AND OPERATION

3.1 MECHANICAL INSTALLATION

Units may be obtained in various physical configurations. Figures 3-1 through 3-10 show the outline dimensions and other installation requirements for the available configurations. Select the proper outline and dimension figure applicable to the unit purchased. Be sure to observe the applicable special procedures and precautions given with the illustration. Although the units are designed to operate in free air at quite a high ambient temperature, it is advisable, if possible, to mount the unit on a surface made of material that can serve as a heat sink. For a plug-in unit mounted in a rack, be sure that the rack has adequate ventilation.

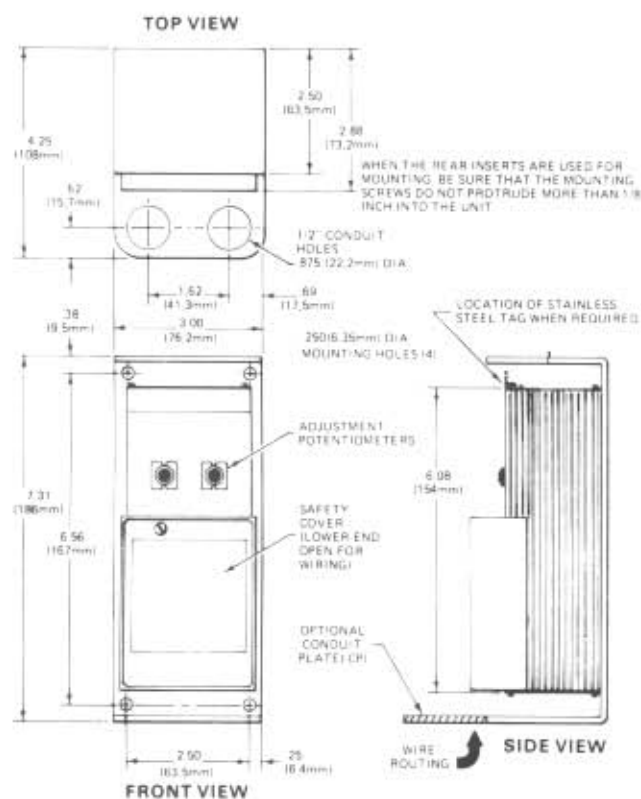

NOTES

- 1 Complete Model No. and Serial No. are permanently marked on identification plate located at upper end of terminal blocks.
- 2 When extra-compact mounting is required for rack or portable installation, C-shaped mounting bracket may be removed and two threaded inserts (located 4.00 inches apart) may be used for mounting, using 6-32NC machine screws.

Figure 3-1. Standard Unit and Unit with CP Option, Outline and Dimension

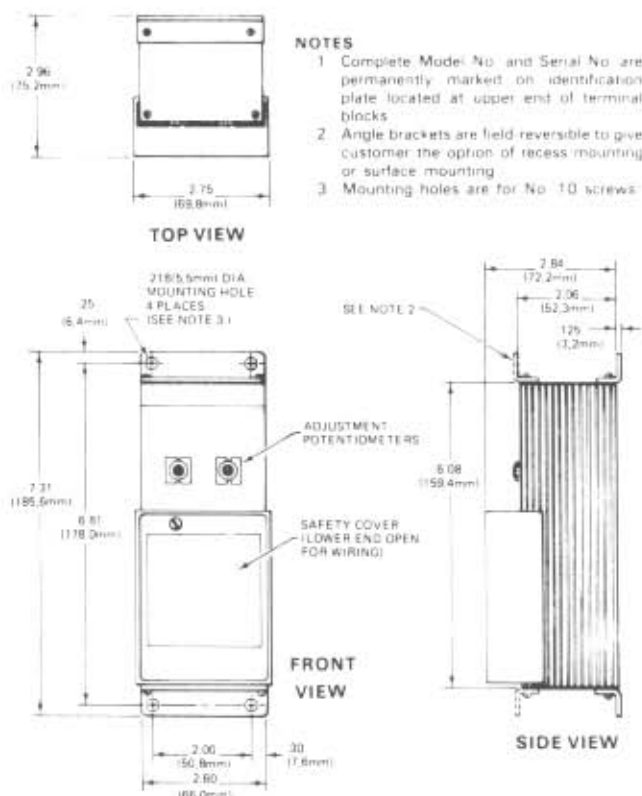

NOTES

- 1 Complete Model No. and Serial No. are permanently marked on identification plate located at upper end of terminal blocks.
- 2 Angle brackets are field-reversible to give customer the option of recess mounting or surface mounting.
- 3 Mounting holes are for No. 10 screws.

Figure 3-2. Standard Unit With Angle Brackets (AB) Option, Outline and Dimensions

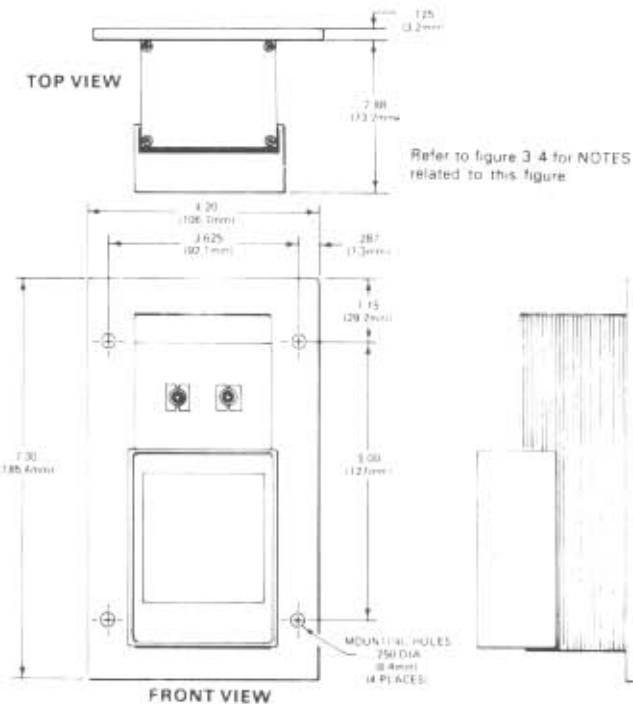
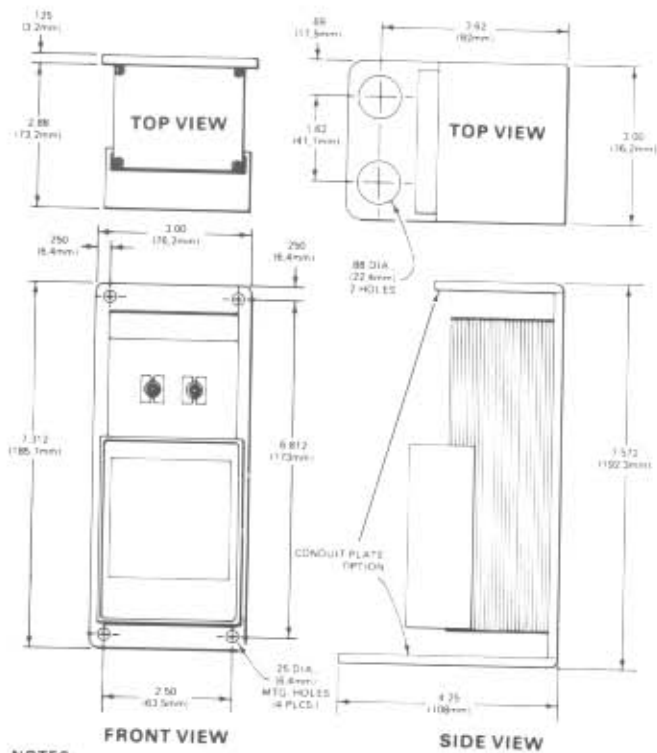
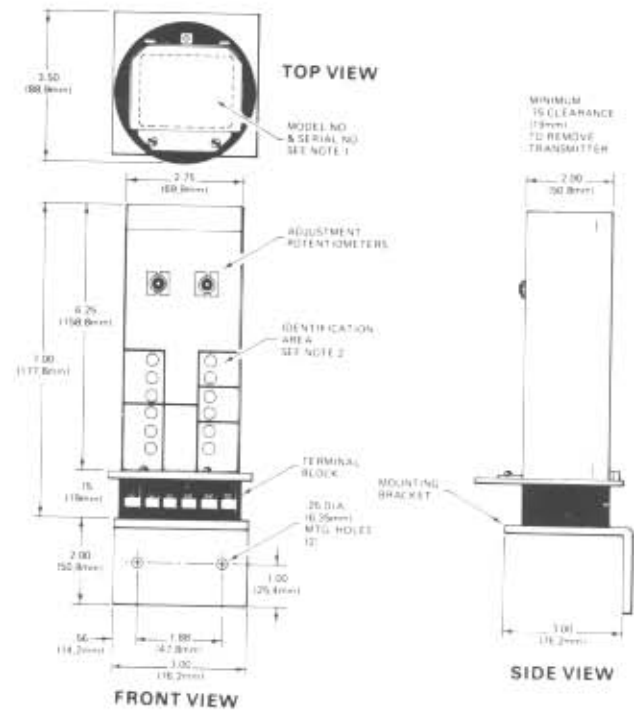

Figure 3-3. Standard Unit, With Adapter Plate (RAA) Option, Outline and Dimensions



- NOTES:**
- 1 Use two threaded inserts (located 4.00 inches apart on back of standard transmitter for mounting adapter plate to transmitter. Use 6-32 NC machine screws)
 - 2 Unit to adapter plate mounting screws should not protrude more than $\frac{1}{8}$ " into the unit

Figure 3-4. Standard Unit With Adapter Plate (RAT) Option, Outline and Dimensions



- NOTES:**
- 1 Identification area on top of unit case carries complete model number and serial number
 - 2 Identification area on front of transmitter case gives electrical connection information

Figure 3-5. Standard Unit With Plug-In STD Transmitter (PST) Option, Outline and Dimensions

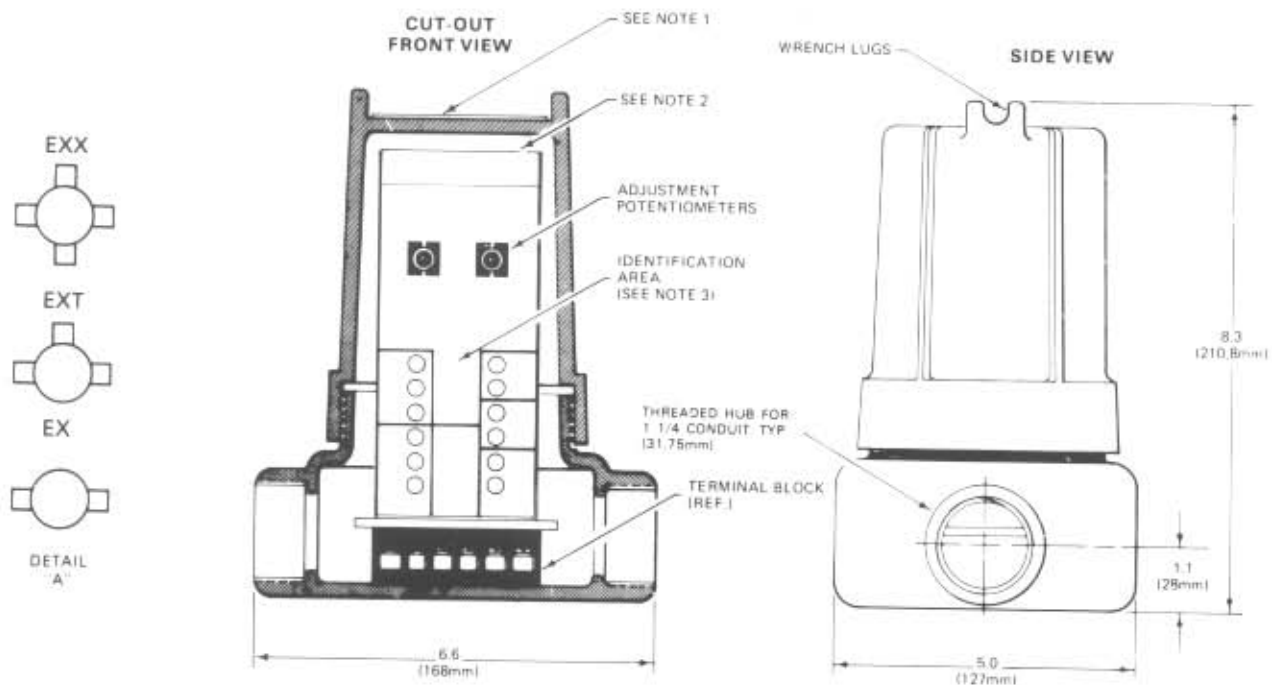

- NOTES:**
- 1 Top of cover has metal label carrying unit type (e.g. TCT, MVT) and equipment number (if any)
 - 2 Identification area on top of unit case carries complete model number and serial number
 - 3 Identification area on front of unit case gives electrical connection information
 - 4 "EX" housing (two conduit hubs) is shown above. Similar housings with three or four hubs is illustrated in detail A. Housings are cast aluminum alloy and meet NEMA specifications for Class I, Groups C and D and Class II, Groups E, F, and G.

Figure 3-6. Standard Unit in Explosion-Proof Enclosure, Outline and Dimensions

SECTION 3

INSTALLATION & OPERATION

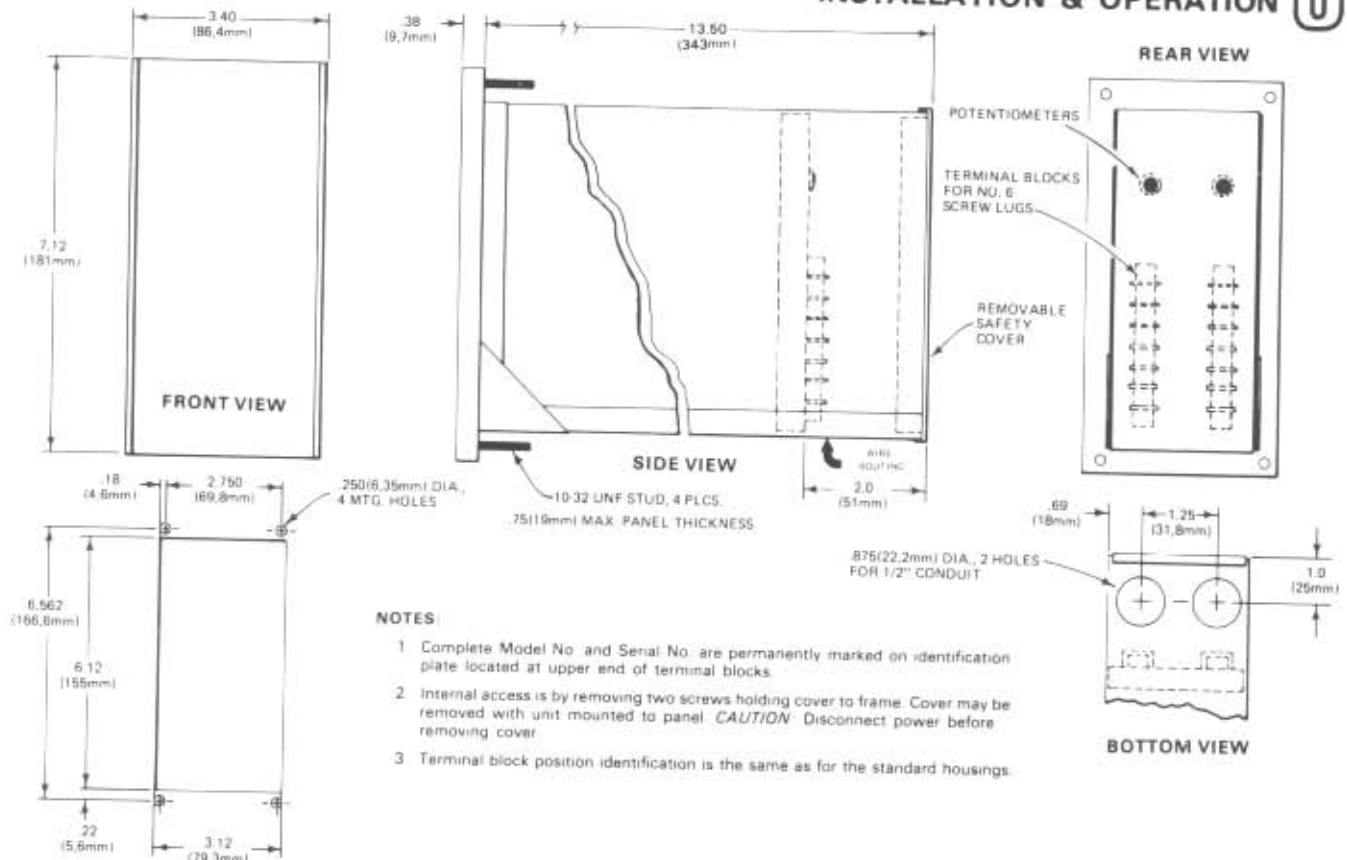

Figure 3-7. Standard Unit with Panel Mount Enclosure (PM) Option, Outline and Dimensions

195-701-00A
AXB MULTIPLIER MODULE

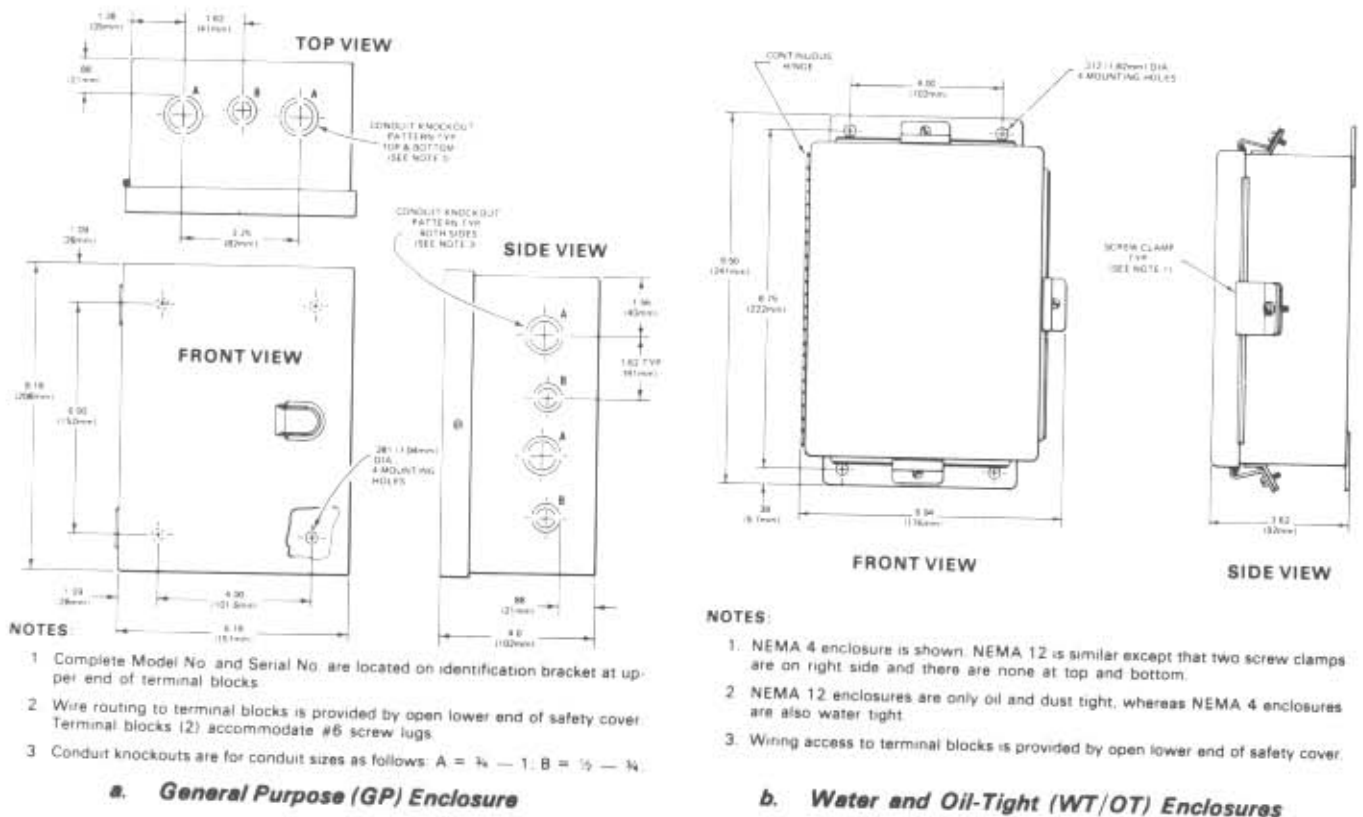
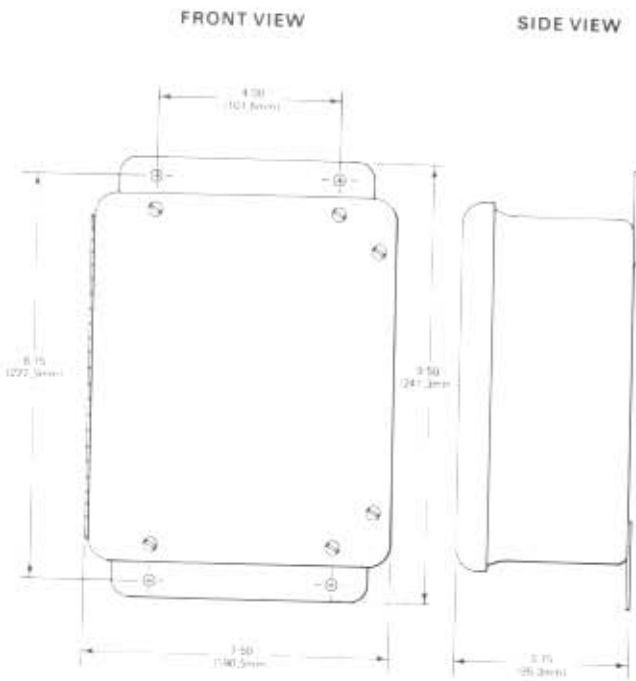

Figure 3-8. Standard Unit in NEMA Boxes, Outline and Dimensions



- NOTES:**
1. All exposed metal hardware is type 302 stainless steel. Boxes are hinged on the long side unless otherwise specified.
 2. All boxes include a one piece closed cell neoprene gasket.
 3. Standard color is machine tool grey. Boxes are molded from pigmented polyester resins with the color throughout the box wall for a maintenance-free installation.

c. Corrosion-Proof (FG) Enclosure

Figure 3-8. Standard Unit in NEMA Boxes, Outline and Dimensions (Cont.)

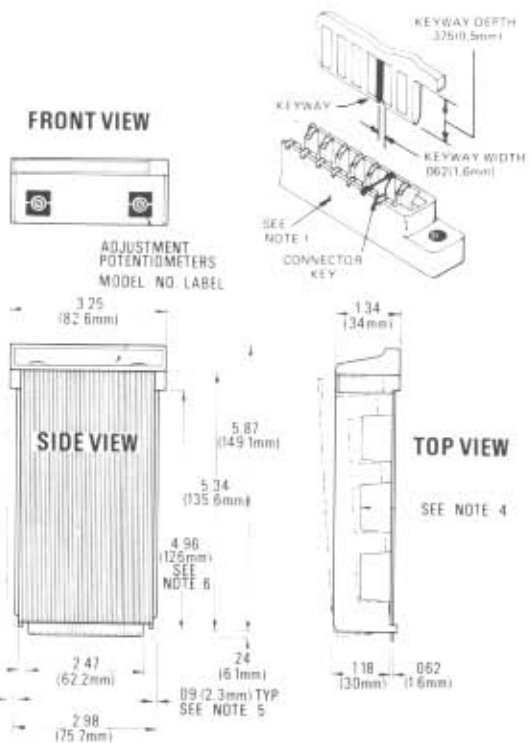

- NOTES:**
1. Connectors used must have contacts on .156 (3.96mm) centers, with contacts for both surfaces of board (recommended type: Viking part no. 2VK155/1-2).
 2. Maximum card insertion depth in connector is .350 (8.89mm).
 3. Minimum width of connector insertion slot is 2.470 (62.70mm).
 4. Removable plastic safety cover, 2.800 (71.12mm) wide.
 5. Maximum card edge guide insertion depth is .09 (2.29mm). Guides must be non-conductive.
 6. Card edge-guides cannot extend beyond here.
 7. Card extender part no. 350-513-00 is available for testing unit while in operating position.

Figure 3-9. Plug-In Unit, Outline and Dimensions

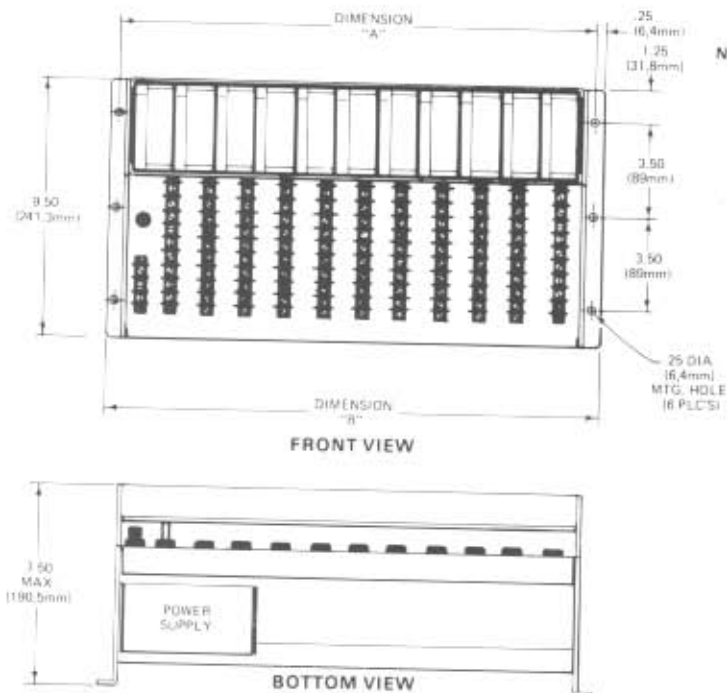

- NOTES:**
1. Mini surface mounted card rack accommodates as few as 5, and as many as 15 plug in units.
 2. Empty positions may be closed by means of filler cards, P/N 350-213-00.
 3. Connections are keyed to assure units will be plugged into proper position. Keying may be changed in the field if the system configuration changes.
 4. Eleven position card rack is illustrated. Dimensions for mounting larger or smaller racks may be found in the table.
 5. 24V power supply, shown, is capable of powering all models in card rack. Input specification, 117 VAC \pm 10%, 50/60 Hz, approximately 40 watts.

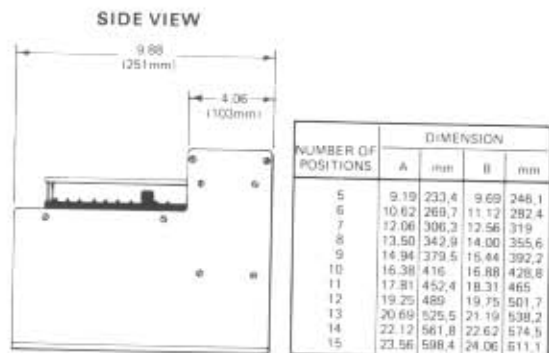
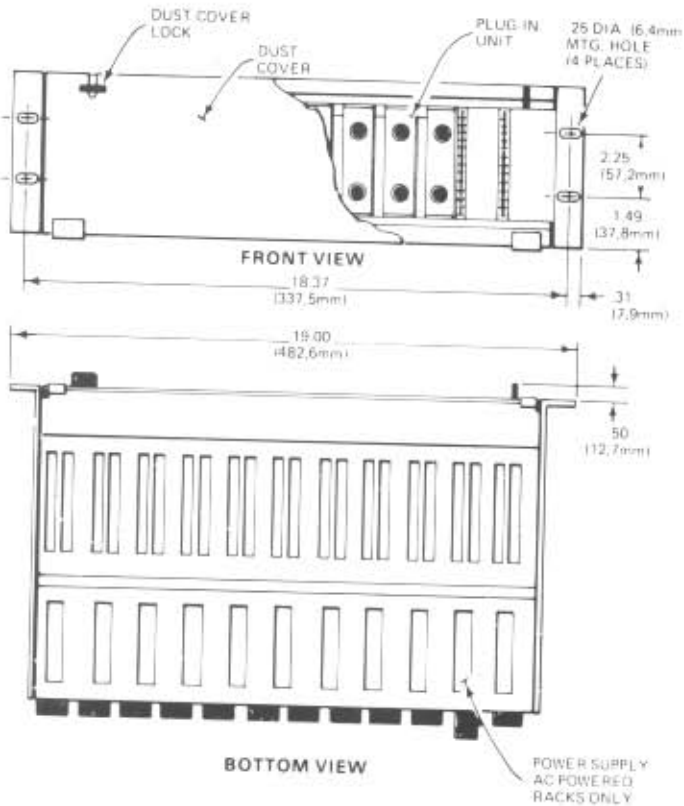

Figure 3-10. Surface Mounted Card Racks (SMR), Outline and Dimensions

SECTION 3

INSTALLATION & OPERATION



NOTES

- 1 Connectors are keyed to assure units will be plugged into proper position. Keying may be changed in the field should the system configuration change.
- 2 This enclosure is designed to mount in a standard 19-inch rack with EIA hole pattern.
- 3 Surface mounting card racks for use in NEMA type enclosures are also available. Contact factory for further details of card racks and card rack assemblies.
- 4 Barrier strip connectors are CSA approved.
- 5 Empty positions may be closed by means of filler cards. Part No. 350-213-00 which must be ordered individually in quantity required.
- 6 24 volt power supply furnished capable of powering a typical complement of unit to fifteen modules. Input specification 117 volts \pm 10% 50-60 Hz approximately 40 watts.



a. Eleven-Position Card Rack

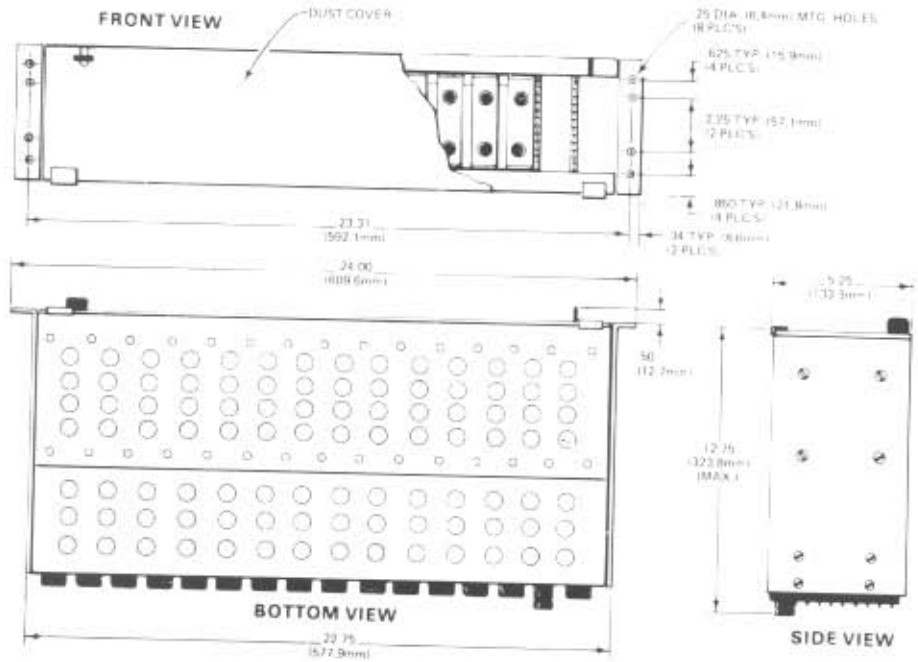

b. Fifteen-Position Card Rack

195-701-00A
AXB MULTIPLIER MODULE

Figure 3-11. Rack-Mounted Card Racks (RMR) Enclosure, Outline and Dimensions

3.2 ELECTRICAL CONNECTIONS

All electrical connections to standard units are made to the terminal blocks on the unit. On plug-in units, the electrical connections are made to terminals on the mating connector for the unit. Terminals used for standard units and their options are defined in the following paragraph.

3.2.1 General Wiring Information

No special wire or cable is required for signal connections to the unit. To avoid transients and stray pickups, it is recommended that twisted conductors be used where they are run close to other services (such as power wiring). Electrical connections to the units fall into two major categories: connections to all standard units with terminal blocks, and connections to plug-in units and their associated enclosures.

Wiring Information for All Standard Units With Terminal Strips and Blocks. Standard units with terminal strips or terminal blocks have terminals supplied with 6-32 screws long enough to easily accommodate three spade-lug connectors. Standard units with snap-off plastic covers have an opening in the bottom of the cover. Dress all wiring to and from the terminals through this opening. Spade lug connectors are recommended for all wire terminations. Figure 3-12 illustrates the

terminal strip locations and identification for the standard units and the terminal block identifications for the explosion proof and PST configurations. Table 3-1 provides the complete labeling nomenclature for standard unit and any available electrical options. Terminal labeling appears next to the terminal it identifies on standard units. For PST and explosion proof units, terminal labeling is marked on the front of the unit housing with the referenced terminals identified numerically.

Wiring Information for All Units in NEMA Boxes. Units mounted in NEMA boxes are standard units with or without the options listed in Table 3-1. NEMA boxes for OT or WT options do not have conduit holes fittings or knockouts. Conduit access must be provided by fittings such as Myer Scru-Tite or equivalent.

General Purpose (GP) enclosures have conduit knockouts for various sizes of conduits from 1-inch down to 1/2-inch. Corrosion-Proof (FG) enclosures require special attention with ground connections. Since enclosure material is polyester resin, conduit cutouts may be cut with a punch or hole saw. Ground continuity may be obtained in two different ways. If a metal panel is used, ground can be made between the metal con-

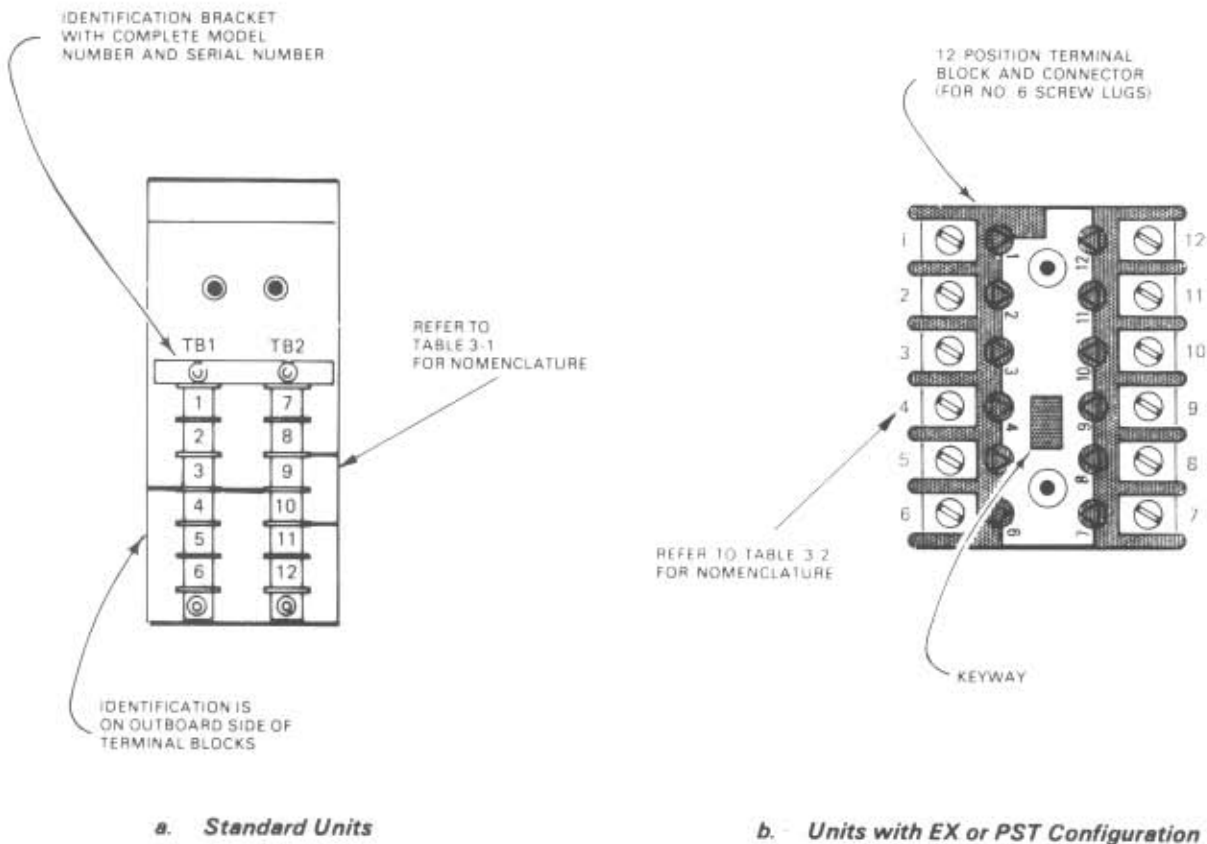

Figure 3-12. Terminal Strips and Terminal Blocks Identification

TABLE 3-1. TERMINAL NOMENCLATURE

Options (Note 1)	Terminal Positions (See Figure 3-12)											
	1	2	3	4	5	6	7	8	9	10	11	12
NONE		GND		(—) DCC	(+) DC		+A	—A	+B	—B	(+) OUT	(—) OUT
AC				ACC	AC		+A	—A	+B	—B	(+) OUT	(—) OUT
SC (Output)		SC	SC									
SC (Input) (Note 2)												
TX		+TX										

NOTES:

1. Labeling shown here may be combined. The combination may include standard labeling and one or more options. Combinations of options may cause labeling positions to change, but nomenclature will remain as shown.
2. Terminal nomenclature not affected by this option. SC resistor is mounted across +A and —A or across +B and —B terminals.

Legend:

DC	+DC Power Input	± A	A Signal Input
DCC	—DC Power Input	± B	B Signal Input
GND	Chassis Ground	± OUT	Signal Output
AC	AC Power Input	SC	SC Resistor
ACC	AC Power Return	+TX	Excitation Power Output

195-701-00A
AXB MULTIPLIER MODULE

duit locknut and the panel at enclosure entry and exit. If the enclosure is used without the back panel, a jumper between the conduit entry and exit is necessary to maintain ground continuity. Remove snap-off plastic cover to access terminal strips.

Wiring Information for Plug-In Units. Plug-in units and card rack electrical connections are made to terminals on the mating connector for the unit or the card rack terminal strips. Figure 3-13 illustrates the terminal strip connections and their

numerical reference designator. Table 3-2 provides a complete terminal nomenclature for both Plug-In and Rack assemblies.

3.2.2 Power Connections

Units are designed to operate from either a DC or AC power source. Refer to paragraph 1.6 for information on how to use the model number to determine the type of power required.

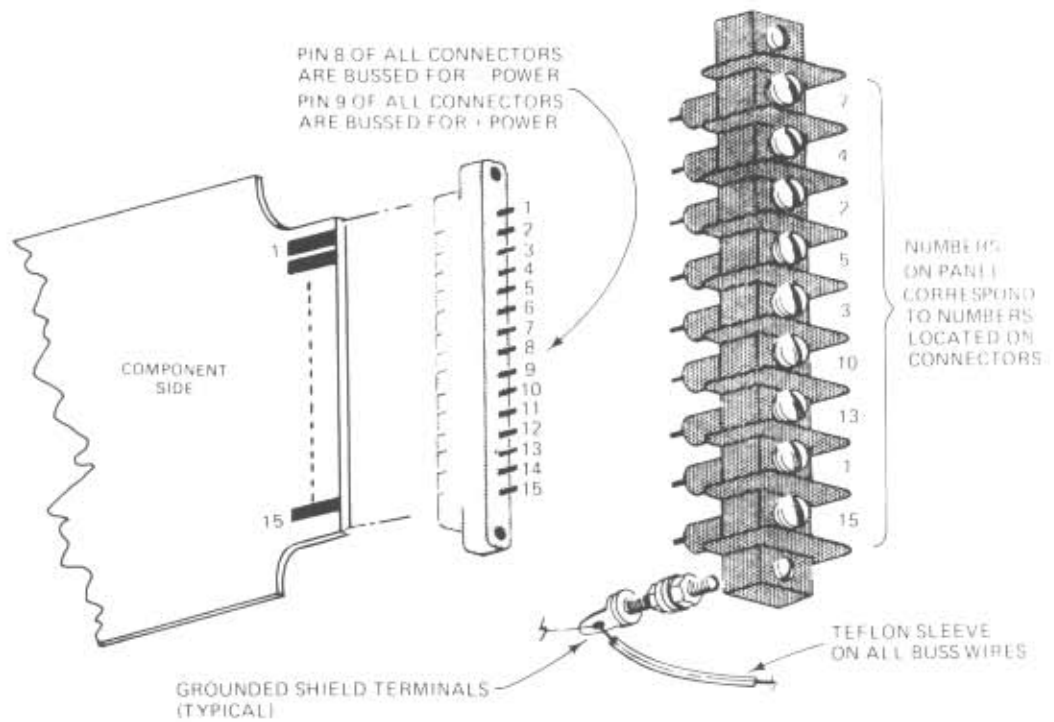

Figure 3-13. Plug-In Connectors and Terminal Strips Wiring and Identification

TABLE 3-2. CONNECTOR PINS AND TERMINAL ASSIGNMENTS FOR PLUG-IN UNIT AND CARD RACKS

Options	Terminal Positions (See Figure 3-13)														
	1	2	3	4	5	6	7	8	9	10	11	12	13	14	15
NONE	+B		+A	(+) OUT			(-) OUT	(-) DCC	(+) DC	-A				-B	
SC (Output)		SC			SC										
TX					+TX										

KEYWAYS

Legend:

DC	+DC Power Input	± B	Signal Input
DCC	-DC Power Input	± A	Signal Input
GND	Chassis Ground	± OUT	Signal Output
+TX	External Excitation Power Output	SC	Selectable Current Resistor

DC-powered units. On these units the DC terminal is connected to the + (positive) side of the source, and the DCC terminal is connected to the — (negative) side. The DC source should be regulated to within $\pm 10\%$ of the nominal voltage and should be capable of delivering 5 watts.

AC-Powered Units. These units require 117 volts AC $\pm 10\%$, 50/60 Hz at 5 VA of nominal power or 220/240 VAC optionally. The AC terminal should be connected to the ungrounded or "hot" side of the supply, if possible, and the ACC terminal is connected to the common or neutral. The GND terminal is the mechanical case connection.

Rack Power Connections Connect power input wires to the appropriately labeled terminals of the 3-terminal connector strip. The third terminal on strip is chassis ground.

3.2.3 Connections On Units With SC Option

On units with the SC (selectable input current) option, connect the input selectable current resistor to the +B and —B or the +A and —A terminals. Connect the output selectable current resistor to the terminals marked SC, or those specified in Table 3-1. The current range is marked on the body of each resistor. If provided, the selectable current resistors for a plug-in unit should be mounted externally either at the terminal block of the card rack, or soldered to the appropriate terminals on the PC connector. See Table 3-2 for correct connections.

3.2.4 Connections on Units With TX Option

On units with TX option, connect the positive output lead from the field mounted transmitter to the +TX terminal on the unit. Connect the minus output lead from the transmitter to the +A input on the unit. Figure 3-14 illustrates this connection. Numbers in parentheses refer to plug-in units.

3.3 OPERATION AND PERIODIC OBSERVATION

Once calibrated and installed, the unit may be operated unattended. The only controls on the outside of the unit are the SPAN and ZERO potentiometers, which, after initial adjustments, need no further attention. There are no indicators on the unit. Because the circuit uses highly reliable solid-state components with no moving parts, the unit should operate virtually maintenance-free for a long period of time. However, if a malfunction should occur, refer to Section 5 for maintenance information.

A periodic check of input and output connections is recommended every six months to ensure continued dependability of operation.

A unit may become warm during operation, especially where the ambient temperature is rather high. This is perfectly normal and should not be a cause for alarm unless a malfunction is also observed.

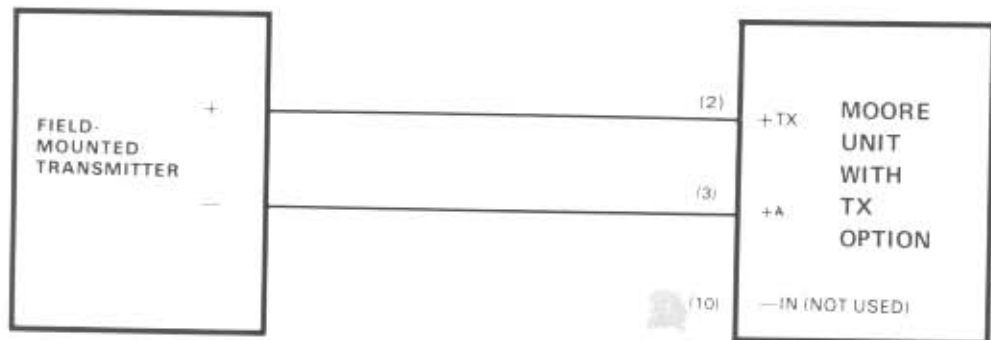

Figure 3-13. TX Option Connections

THEORY OF OPERATION

4.1 INTRODUCTION

This section describes the unit operation. An overall view of the unit function based on the block diagram of Figure 4-1 introduces the user to the unit functional elements. This functional analysis is further detailed in the circuit description paragraphs that follow. Each of these paragraphs also contains a detailed description of the circuit operation. These descriptions are based on the schematic diagram included in Section 6, Unit Documentation.

Components reference designators are listed here for both standard and plug-in models. The standard nit reference designator is listed first. This information is followed by the reference designator for the plug-in unit in parentheses and italics. If both reference designators are the same, it is listed only once.

A rapid familiarization of the unit can be obtained by reading the general functional description (paragraph 4.2) and the functional section of the circuit description paragraphs entitled "General." The "Detailed" section of these paragraphs provides sufficient data so that troubleshooting, if required, can be performed intelligently and rapidly.

4.2 EQUIPMENT FUNCTIONAL DESCRIPTION

Input signal A (as a percent) is applied to a buffer input amplifier, and the proportion of the output that drives the next stage is controlled by solid-state switches. Input signal B (also as a percent) is applied to another buffer input amplifier. The amplitude of input signal B (from the output of its buffer amplifier) is compared with that of an internally-generated ramp by a comparator that provides drive to the switches. This method of generating the drive to the switches and the arrangement of the switches themselves cause the drive from the A buffer amplifier to the following stage to be proportional to the product of the span of the A and B inputs. This driving signal is linearly amplified to produce an output that is likewise proportional to the product of the spans of input A and input B.

4.3 POWER SUPPLY CIRCUIT DESCRIPTION (Standard Units Only)

General: Units are usually supplied for use with either an AC or DC power input, but may accept both if ordered for an AC primary power input with, for example, a 24-volt battery backup as a DC secondary power input. On units for use with an AC power input, the power supply typically develops a 24-volt DC output that is applied to the input of the power inverter. On units intended for a DC power input, the power is applied directly to the input of the power inverter (see paragraph 4.4), with diode protection to prevent damage to the power inverter components, if the DC power input is accidentally connected with reversed polarity. Units with battery backup are normally AC-powered and the DC power source is used only when the AC power source drops below a level that will maintain a 24-volt (or other normal) DC output from the power supply.

A 400 milliamp fuse may be placed in series with the +DC input as illustrated in schematic diagram 195-451-00. This configuration, used in the fuse option (FU), protects the unit from damage where DC voltage may fluctuate enough to cause excessive current drain on the unit.

Detailed: Units operated from an AC power source use a power supply consisting of a power transformer, rectifier and filter to produce a DC output. Referring to the schematic diagram, VS1 is connected across the primary of power transformer T1 and suppresses transients that may be present on the power line. The output from the series-connected secondaries of T1 is rectified by CR7, a full-wave rectifier bridge, thus producing a pulsating DC voltage applied to the input of the regulator board PC2.

4.4 DESCRIPTION OF POWER INVERTER CIRCUIT (Standard and Plug-In Units)

General: The power inverter is a transformer-coupled multivibrator oscillating at approximately a 3 KHz rate. Because the core of the transformer is saturated, a square wave of reasonably constant amplitude is generated. This signal can be observed at the collector of Q1 or Q2. The transformer has four secondary windings isolated from each other. Only two of these are used to produce in-

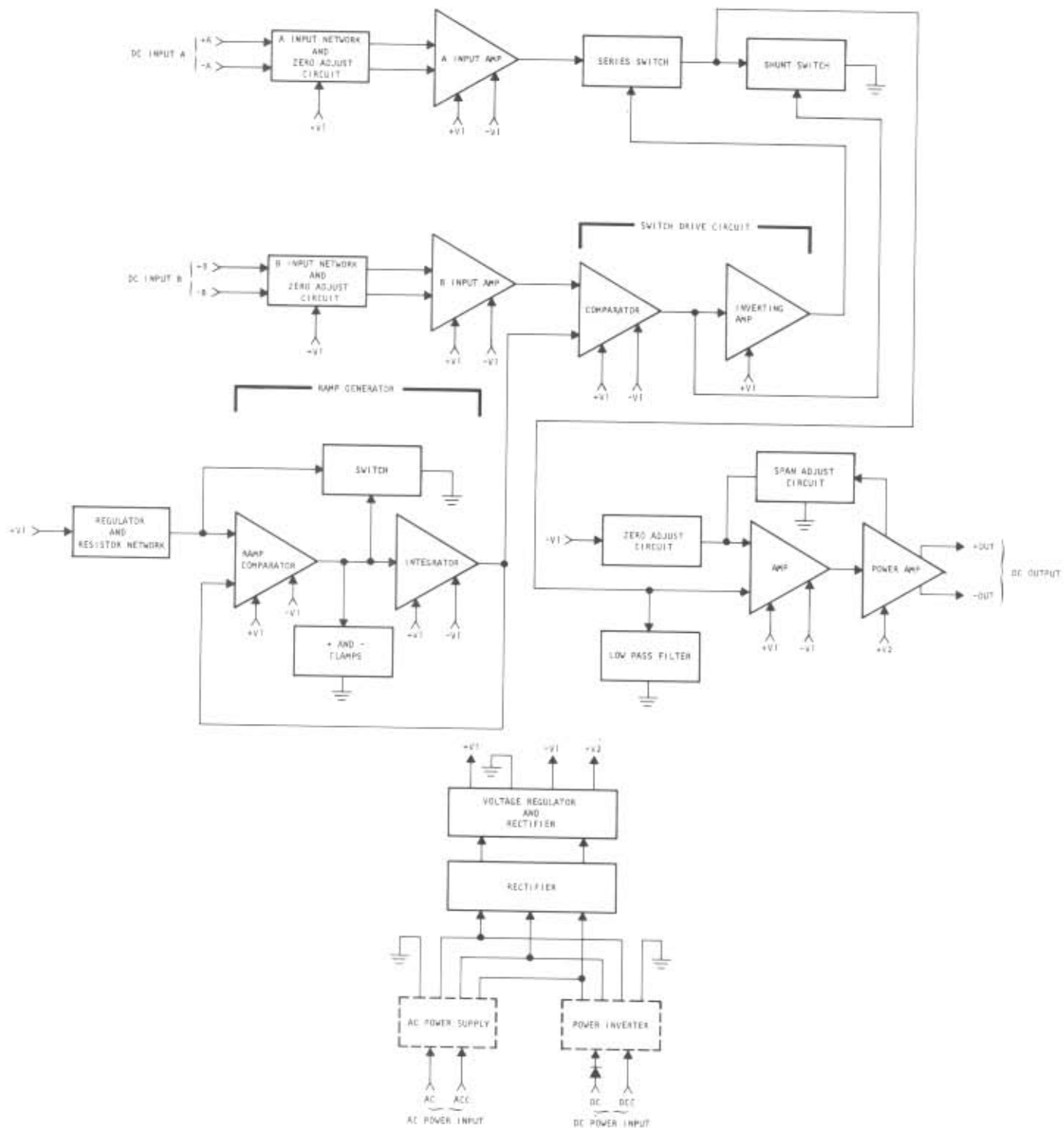

Figure 4-1. Unit Block Diagram

dependent square wave outputs. These outputs, instead of the outputs from the AC power supply, are then applied to the rectifier and regulator, which function in the usual manner. A diode in the DC (positive) lead will prevent damage to components in the power inverter if the DC primary source is accidentally connected with incorrect polarity.

Detailed: The components of the power inverter

are mounted on a printed circuit board attached to the main board for standard units and are mounted directly on the main board for plug-in units. Drawing 400-404-00 is the schematic diagram of the power inverter (PCA) used on a standard unit. When a standard unit is ordered for use with DC power, the power inverter is used instead of the AC source T1 shown on the unit schematic diagram. The DC applied to the power inverter is converted to a square wave of approximately 3

KHz by Q1, Q2, and the primaries of T1, functioning as a DC-to-AC inverter. Filter L1-C4 (C11) prevents the 3-KHz signal from getting back into the external DC source. CR1 (CR7) provides protection against damage from inadvertent application of DC of incorrect polarity. The square-wave output from center-tapped secondary 8-13 is applied to CR17 and CR18 (CR6, CR5), and that from secondary 17-16 is applied to a half-wave rectifier.

4.5 DESCRIPTION OF RECTIFIER AND REGULATOR CIRCUIT

General: The rectifier accepts the outputs from either the AC power supply or the power inverter and produces unregulated positive and negative voltages (of equal value with respect to ground). The regulator reduces these voltages to the required operating values and regulates them against changes with load or line-voltage changes. Although physically on the regulator assembly, another rectifier produces a higher unregulated output as operating voltage for the power amplifier.

Detailed: On all standard units, the components of the regulator circuit are mounted on a printed circuit board attached to the main board, while the main rectifier is mounted on the main board. On plug-in units all components are mounted on the main board. CR7 used in the AC power option of standard units only (unit schematic diagram) consists of two sets of full-wave rectifiers arranged to produce both positive and negative DC outputs (with respect to the grounded center tap of the transformer winding that feeds the rectifier). The positive and negative DC outputs from CR7 for AC power option or from CR6 and CR8 (CR6, CR5) for DC power input, are applied to pins 5 and 6 of the power supply regulator for standard units only.

On standard units the regulator consists of two filters and voltage regulators, one each for the positive and negative outputs from CR7 and a half-wave rectifier and filter. On plug-in units, the regulator consists of zener diodes CR3, CR4, and pass transistors Q4, Q3. The unfiltered positive output from CR7 (CR6, CR5) or from the PCA on standard units DC power input, is filtered by C203 (C6) and then regulated to +12 volts output by pass transistor Q202 (Q3), the base of which is clamped at 12 volts by CR203, (CR3).

Similar action to produce —12 volts output is ac-

complished by C202 (C7), Q201 (Q4), and CR202 (CR4). Half-wave rectifier CR201, CR204 (CR8) and filter C201 (C10) produce a higher unregulated positive voltage (approximately +38 volts) from the transformer winding that is not center-tapped. This higher voltage is used to power the output amplifier.

4.6 RAMP GENERATOR CIRCUIT DESCRIPTION

General: The ramp generator produces a periodically varying signal that is compared with the DC output from the B input amplifier. The resulting signal then drives switches that control the signal from the A input amplifier that is applied to the following amplifier so this drive signal is proportional to the product of the spans of the A and B input signals.

The ramp generator produces an output that periodically increases at a constant rate to a specific maximum positive value and then decreases at the same rate to zero. Operation of the ramp generator is at a constant frequency. The output of the generator is applied to one side of the comparator that produces the basic drive signal for the switches that control the signal from the A input amplifier.

The main elements of the ramp generator are a ramp comparator and integrator. This circuit also includes a switch and plus and minus clamps. One side of the ramp comparator is fed with a fixed positive voltage derived from the +V1 voltage. Assume that the output of the ramp comparator is initially at a fixed negative value determined by the negative clamp. This output is applied to the switch, keeping it turned off, and also the integrator, causing it to produce an increasing output. The rising integrator output is applied to the other side of the ramp comparator. When the rising integrator output just equals the fixed positive voltage applied to the opposite side of the ramp comparator input, the comparator output rapidly switches to a fixed positive value, thus turning on the switch and removing the fixed positive voltage as one input to the comparator. This same positive output from the ramp comparator also drives the integrator and thereby drives its output toward zero.

With the switch turned on, the ramp comparator is driven only the decreasing output of the integrator. When the integrator output becomes

zero, the output of the ramp generator rapidly changes to its negative value, turning off the switch and again allowing the fixed positive voltage applied to one side of the ramp comparator to control the ramp generator. Thus, a new ramp cycle is initiated.

Detailed: In the ramp generator, IC3 (IC4) and associated components form the ramp comparator, Q2 (Q11) serves as the switch, and IC1 (IC6) and its associated components act as the integrator. CR9, fed from the +12-volt source through R19 (R45), produces as a regulated voltage of +6.2 volts, which is applied to pin 2 (the inverting input) of IC3 (IC4). If the external signal applied to pin 3 of IC3 (IC4) from the output of IC1 (IC6) is assumed, for the moment, to be zero, IC3 (IC4) will be driven only by the positive signal applied to pin 2 and thus produce a negative output signal at pin 6. This negative output is applied through R1 (R46) to the base of Q2 (Q11) and turns off this switch. CR1 (CR12) limits the negative voltage that can be applied to the base of Q2 (Q11) to approximately 0.6 volt. The output from IC3 (IC4) is also applied through R3 (R46) to CR2 (CR11) and clamped at this point to -6.2 volts. The clamped signal is applied through R4 (R48) to pin 2 (the inverting input) of IC1 (IC6). Under the influence of this signal and the action of C1 (C5), IC1 (IC6) produces an output that begins to rise at a constant rate, and this output is applied through R35 to pin 3 (the non-inverting input) of IC3 (IC4). When the rising signal at pin 3 of IC3 (IC4) becomes greater than the positive voltage applied to pin 2, the output of IC3 (IC4) rapidly changes to a positive value. This positive output of IC3 (IC4) turns on Q2 (Q11), which short circuits pin 2 of IC3 (IC4) to ground and thus removes the effect that the fixed positive voltage had in controlling the action of the ramp comparator. Now feedback from the integrator output to pin 3 of IC3 (IC4) regeneratively locks IC3 (IC4) to keep its output positive (under the conditions just described). The positive output of IC3 (IC4) is clamped to +6.2 volts by CR3 (CR10), and the resulting positive signal is applied to pin 2 of IC1 (IC6). Since the signal applied to the inverting input of IC3 (IC4) is now positive, the output of IC1 (IC6) begins to decrease toward zero at the same rate it originally increased from zero to its maximum positive value. Because pin 2 of IC3 (IC4) is grounded by Q2 (Q11) (which is now turned on), the output of IC3 will remain positive until the ramp output from IC1 (IC6) reaches zero. When this occurs, the output of IC3 (IC4) again reverses polarity and becomes negative, turning off Q2 (Q11) and starting a new ramp cycle. Both IC3 (IC4) and IC1 (IC6) operate from +12 volts and -12 volts.

4.7 SWITCH DRIVE CIRCUITS DESCRIPTION

General: The switch drive circuit consists of a comparator and inverting amplifier. One side of the comparator is driven by the output of the B input amplifier, and the other side is driven by the output from the integrator in the ramp generator. As long as the drive from the ramp generator is less than that from the B input amplifier, the comparator produces a negative output that turns off the shunt switch and inverting amplifier. The output at the inverting amplifier turns on the series switch. When the output of the ramp generator becomes slightly greater than that of the B input amplifier, the comparator produces a positive output that turns on the shunt switch and the inverting amplifier, thus turning off the series switch. The switches remain in these states until the ramp output again falls below the output of the B input amplifier, at which time the series switch is again turned on and the shunt switch turned off. The process then repeats.

Detailed: The switch drive circuit consists of comparator IC6 (IC2) and inverting amplifier Q1 (Q10). The ramp output from IC1 (IC6) is applied through R2 (R31) to pin 3 (the non-inverting input) of IC6 (IC2) and output from B input amplifier IC2 (IC3) is applied through R26 (R19) to pin 2 (the inverting input). When the ramp signal is just beginning to rise from zero, it is lower in amplitude than the signal from IC2 (IC3) which is proportional to the span of the B input signal applied to the unit. Under this condition, IC6 (IC2) produces a negative output that is applied through R22 (R18) to turn off Q3 (Q8), and is also applied through R22 (R31) to turn off Q1 (Q10). With Q1 (Q10) off, the positive voltage at its collector is applied through R23 to Q4 (Q9), turning on this switch. Q4 (Q9) and Q3 (Q8) remain in their respective on and off states until the ramp output from IC1 (IC6) rises above the output from IC2 (IC3) and causes IC6 (IC2) to reverse the polarity of its output. At this point, Q4 (Q9) and Q3 (Q8) reverse their states and remain in their new states until the ramp output again becomes less than the signal applied to pin 2 of IC6 (IC2). IC6 (IC2) operates from +12 volts and -12 volts, and Q1 (Q10) operates from +12 volts.

4.8 A AND B INPUT NETWORKS AND ZERO ADJUST CIRCUITS DESCRIPTION

General: The A and B inputs each have an input network and zero adjust circuit. Each input network provides the corresponding input signal with the proper termination, and each input signal is applied to an input amplifier. Each zero adjust

circuit, which operates from +V1, adds an adjustable positive voltage to the inverting input of the associated input amplifier. This voltage modifies the live zero (if present) of the resulting output from the amplifier so the span of that output signal corresponds to that of the physical quantity represented by the input signal.

Detailed: Resistor R11 (R56) provides a current A input signal with the proper termination, and R6 (R57) performs the same function for a current B input signal. The A zero adjust circuit consists of the A INPUT ZERO potentiometer and R41, R42 (R3, R4) connected across +6.2 volts, which is regulated by CR4 (CR2) and derived through R32 (R24) from +12 volts. The B zero adjust circuit consists of the B INPUT ZERO potentiometer and R40, R44 (R6, R7) connected across a -6.2 volt source regulated by CR5 (CR1) and derived through R47 (R23) from -12 volts. When the RO option is selected, resistors R42, R44 (R4, R7) are omitted and the connections are not made. Instead, resistors R45, R43 (R5, R8) are inserted, making the respective connection to the opposite supplies.

Each INPUT ZERO (A or B) potentiometer is adjusted so the voltage at its wiper, when combined through a resistor either R28 (R4) or R30 (R21) with the feedback signal at pin 2 of the associated input amplifier, causes that amplifier to produce the required output. Thus, the live zero of the corresponding output from the input amplifier (A or B) is modified so the span of that signal corresponds to that of the physical quantity represented by the A or B input signals.

4.9 B INPUT AMPLIFIER CIRCUITS DESCRIPTION

General: The B input amplifier is an operational amplifier used as a buffer to isolate the B input signal source from the following load, which is one input of the comparator. Feedback is used to establish the amplifier operation.

Detailed: Integrated circuit IC2 (IC3) is the B input amplifier. The B input signal is applied through R7 (R44) to pin 3 (the non-inverting input) of IC2 (IC3). Feedback from the output at pin 6 is applied through R8 (R20) to pin 2 (the inverting input) and is combined with the voltage at the wiper of the B INPUT ZERO potentiometer. Since this potentiometer is in the return path from pin 2 of IC2

(IC3) to ground, the gain of IC2 (IC3) varies with adjustment of the B INPUT ZERO potentiometer. IC2 (IC3) operates from +12 volts and -12 volts.

4.10 A INPUT AMPLIFIER AND SWITCHES

General: The A input amplifier is an operational amplifier used as a buffer to isolate the A input signal source from the following load. Feedback is used to establish the amplifier gain and also to achieve high stability of amplifier operation. The output from the amplifier is chopped by the series and shunt switches into a rectangular wave with an instantaneous value, at the junction of the switches, that is either positive or zero. In general, the durations of these values are not equal. The switches are driven so the DC average value of the chopped output from the A input amplifier is proportional to the product of the spans of the A input signal and the B input signal applied to the unit. It should be noted that this average level of the rectangular wave does not appear at the junction of the switches, but is produced by a low-pass filter at the input of the following amplifier.

Several interrelated factors combine to produce a rectangular wave with positive- and zero-voltage durations such that the desired average value will be obtained. First, the average level is proportional to the time during which the series switch is on, relative to the time for one ramp cycle. This is true because it is during this time that the rectangular wave has a non-zero positive value. Because the B input amplifier drives one side of the comparator, the fraction of the ramp period during which the series switch is on is proportional to the span of the B input signal applied to the unit. In addition, the positive amplitude of the rectangular wave when the series switch is on is proportional to the output from the A input amplifier, which, in turn is proportional to the span of the A input signal applied to the unit. Finally, since the DC average value of the rectangular wave produced by the switches is proportional to both the fraction of the ramp period during which the series switch is on (proportional to the span of the B input signal) and the output from the A input amplifier (proportional to the span of the A input signal), it is seen that this DC average is proportional to the product of the values of the spans of the A and B input signals applied to the unit.

Detailed: Integrated circuit IC4 (IC1) is the A input amplifier, and Q4 and Q3 (Q8) serve as the series

and shunt switches, respectively. The A input signal is applied through R12 (R38) to pin 3 (the non-inverting input of IC4 (IC1)). Feedback from the output at pin 6 is applied through R34 (R37) to pin 2 (the inverting input) and is combined with the voltage at the wiper of the A INPUT ZERO potentiometer. Since this potentiometer is in the return path from pin 2 of IC4 (IC1) to ground, the gain of IC4 (IC1) varies with adjustment of the A INPUT ZERO potentiometer. When Q4 (Q9) is on and Q3 (Q8) is off, the DC signal at the same junction of the switches is zero because Q3 (Q8) acts as a short circuit to ground. As was previously explained, the DC average level that is developed from these two pulse levels is proportional to both the output from IC4 (IC1) and the fraction of a ramp cycle during which Q4 remains on, which, in turn, is proportional to the output from IC2 (IC3). Thus, the DC average level that is ultimately produced at the input to IC5 is proportional to the product of the spans of the A and B input signals applied to the unit. IC4 (IC1) operates from +12 volts and -12 volts. The collector of Q3 (Q8) operates from the DC voltage at the input to IC5. This is possible because the time constant of the low-pass filter at that input is long compared with a ramp period.

4.11 FUNCTIONAL DESCRIPTION OF AMPLIFIER

General: The rectangular wave at the junction of the switches is applied to the low-pass filter between one input terminal of the amplifier and ground. From the pulses of the rectangular wave, the filter produces a DC average signal that is applied to this input terminal. The ZERO adjust circuit, which operates from -V1, applies an adjustable negative voltage to the other amplifier input terminal. This voltage causes the amplifier to produce an output that results in the desired output from the unit with 0% signals applied to both the A and B inputs of the unit. Feedback, adjustable through the SPAN adjust circuit, is also applied to this same input terminal of the amplifier and controls the amplifier gain so the unit produces the desired maximum output with 100% signals applied to both the A and B inputs of the unit.

Detailed: The amplifier consists of IC5 and associated components. The rectangular output at the junction of Q4 (Q9) and Q3 (Q8) is applied through R13 (R27) to pin 3 (the non-inverting input) of IC5 and to R14, C3 (R13, C1) connected between this pin and ground. The two resistors from a voltage divider to reduce the pulse to the proper amplitude, and R14 (R13) and C3 (C8) form a low-pass filter that smoothes the applied pulses into a DC average level that actually drives

pin 3 of IC5. An adjustable voltage from the zero adjust circuit is also applied through R16 (R11) to pin 3 of IC5 to establish a zero output level from the unit with 0% input signal applied. The zero adjust circuit consists of R33, R46 (R10, R9). A portion of the output signal from the power amplifier is fed back through R35 (R53) and the SPAN potentiometer through R36 (R49) to pin 2 of IC5 to establish the gain of IC5 and therefore the output of the unit with 100% A and B inputs signals applied. IC5 operates from +12 volts and -12 volts.

4.12 POWER OUTPUT STAGES

General: The power amplifier increases the power level from the output amplifier to produce an output signal that will drive the load in the required manner. For the current ranges, the amplifier uses three transistors to develop the required output. The signal from the output amplifier is used for voltage output. The power amplifier operates from a high DC voltage. The power output stages configuration varies according to the type of unit output selected.

4.12.1 Unit Current Output

Detailed: When a unit is selected with current output, the output of IC5 pin 6 supplies the drive necessary to operate the power output stage. Two transistors Q7 (Q5), Q6 are wired in a Darlington pair arrangement with the load in series with the transistor's power source. A special power supply is provided for this stage (+38V, point C). Transistor Q5 (Q7) is a power transistor capable of handling the high output currents in this configuration. Resistor R35 (R53) generates the feedback signal to IC5. The resistor value varies according to customer-selected current output ranges. Voltage divider R48 (R51), R37 (R52) is a saturation limitation circuit. The resistance ratio is selected for overload protection and limits the output to 150%. Capacitor C4 (C12) is used to filter the output signal from spurious noise generated from the unit or the transmission lines to the external load. In the units with the SCR option on the output, the optional selectable current output resistor R103 replaces R52 (R54).

4.12.2 Unit Voltage Output

Detailed: When the unit is selected with a voltage output configuration, the output signal from IC5 is used as the output drive at the +OUT terminal. Resistors R35 (R53) and the SPAN control form the feedback network of IC5. Capacitor C5 (C13) filters the output signal.

MAINTENANCE

5.1 INTRODUCTION AND GENERAL INFORMATION

This section contains information to aid in the maintenance of the unit. This includes disassembly instructions for all mechanical options, as well as general troubleshooting. Precautions and special techniques required to replace components are also described.

5.2 DISASSEMBLY

When unit troubleshooting is required, it is first necessary to disassemble the unit. The physical configuration of the unit determines the steps to be followed in disassembly. These are described in the following paragraphs.

NOTE

Always identify wires — usually by tagging — before disconnecting existing connections.

CAUTION

DISCONNECT INPUT SIGNAL AND REMOVE POWER INPUT BEFORE DISASSEMBLING UNIT.

5.2.1 Disassembly of Standard Unit and Units With AB or CP Options

To disassemble a standard, AB, or CP unit, remove the unit from its installed position. If the mounting bracket is used, separate it from the unit by removing the two countersunk screws at the rear of the unit. After the unit has been removed from its installed position, disassemble the unit as follows to gain access to the circuit board.

- a. Remove the two front Phillips-head screws at the top of the unit.
- b. Remove the four Phillips-head screws at the bottom of the unit.
- c. Slide the front panel (with the circuit board still attached) down and free of the sides of the case. Points on the circuit board may now be reached for troubleshooting. It is suggested that the case be used as a container for storing the removed hardware.

5.2.2 Disassembly of Unit in NEMA Boxes

Normally electrical connections are made to NEMA boxes through conduits. Units are secured on a mounting plate in the NEMA boxes. The following disassembly instructions apply to the various configurations.

Disassembly of Units in OT, WT and FG Enclosures. Use the following procedures to disassemble unit:

- a. Loosen clamps that hold hinged cover on OT and WT enclosures only, and open enclosure; otherwise loosen screws securing FG cover. Inspect FG gasket for damage and replace if necessary.
- b. Loosen four screws that secure cover on box.
- c. Remove plastic safety cover from unit.
- d. Tag and disconnect wires from unit. On FG units, tag and disconnect ground wire from conduit to mounting post.
- e. Remove four nuts that secure mounting plate assembly into box.
- f. Remove mounting plate assembly from NEMA box.
- g. Loosen and remove mounting nuts that hold units on mounting plate and remove units.
- h. Disassemble unit as described in paragraph 5.2.1.

Disassembly of Units in FG Enclosure. Use the following procedures to disassemble unit:

- a. Open cover on box.
- b. Remove plastic safety cover from unit.
- c. Tag and disconnect wires from unit.
- d. Loosen four mounting screws that hold into box.
- e. Remove four nuts that secure unit mounting bracket assembly to rear of box.
- f. Remove units with attached brackets.
- g. Disassemble units from mounting brackets.
- h. Disassemble unit as described in paragraph 5.2.1.

5.2.3 Disassembly of Units in PA or PST Enclosures

Use the following procedure to disassemble unit:

- a. Remove unit from terminal block by rocking it slightly while pulling upward.
- b. Remove two nuts, screws, washers, holding front panel to bottom PC board (two front bottom).
- c. Remove two side screws from front panel.
- d. Remove one countersunk screw from back-bottom of unit in bottom of PC board.

Terminal block and card connector are keyed to eliminate error when the unit is reinstalled.

5.2.4 Disassembly of Units in EX Enclosures

Use the following procedure to disassemble unit:

- a. Using a bar wrench, attach to wrench lugs and loosen the housing cover from the base.
- b. Unscrew protective cover to expose unit.
- c. Use procedure of paragraph 5.2.3.

5.2.5 Disassembly of PM Units

Use the following procedure to disassemble unit. Refer to Figure 5-1 for parts nomenclature.

- a. Pull out safety cover to expose wiring.
- b. Tag and disconnect wires from terminal strip. If troubleshooting requires access to reverse side of PC board, perform the procedure described in next step.
- c. Remove screws holding cover to frame and lift cover off the case assembly.

CAUTION

WIRE SERVICE LOOP IS SUFFICIENT TO ALLOW PC BOARD AND END PLATE ASSEMBLIES TO BE TURNED OVER. ANY EXCESSIVE MOVEMENT OF THIS ASSEMBLY MAY CAUSE WIRING DAMAGE.

- d. Remove two nuts and washers that secure PC board and end plate into frame and carefully lift and slide board and plate towards terminal panel, out of end holder.

5.2.6 Disassembly of a Plug-In Unit

To remove the cover of a plug-in unit, proceed as follows:

CAUTION

DO NOT LIFT FRONT OF COVER MORE THAN ¼ INCH. EXCESSIVE FORCE APPLIED TO COVER MAY BREAK REAR RETAINING CLIPS.

- a. Gently spread forward locking feet and lift front of cover.
- b. With the front of the cover raised, slide the cover to the rear to disengage it from the plug-in card.

To test a plug-in unit in the operating position, a circuit board extender card (M.I.I. Part No. 350-513-00 or equivalent) is required. The extender card brings the unit forward so components on circuit board are accessible for troubleshooting.

5.2.7 Disassembly of Plug-In Units in Card Racks

Except for SMR, access to units in racks is effected by removing dust cover over plug-in units. Surface Mounted Racks (SMR) do not have a cover over plug-in units since the whole rack may be enclosed into a NEMA box.

5.3 TROUBLESHOOTING

The schematic diagrams include flagged numbers (or letters) at various points in the circuit. Table 5-1 gives the voltages and waveforms at these points for specified input-signal conditions. The assembly drawing shows the physical locations of the parts on the circuit board. Bear in mind that the circuit board is protected with a moisture-resistant coating. Therefore, it may be necessary to use a needle-point probe and exert a fair amount of pressure to break through the coating when it is desired to observe the signal or voltage at a specific point. When connecting a probe to a component on the circuit board, exercise care to make sure the probe does not short-circuit to an adjacent component.

In general, troubleshooting is carried out by tracing the signal with an oscilloscope and referring to the schematic diagrams to determine what component might be causing an observed abnormal indication. If the original symptom was a complete failure of the unit to operate, the most logical components to suspect are those associated with the power supply in the unit (including any voltage regulators). If the unit was producing an incorrect (but not zero) output, check the outputs from the voltage regulator and, if these are normal, apply a standard input signal and trace the resulting signal through the unit.

5.3.1 Plug-In Board Connector Cleaning

Occasionally, modules which have been in service for a long period of time may develop resistive coatings on the gold-plated contacts of the plug-in boards. This coating, if allowed to build up, can cause malfunctions by decreasing the noise margin of a circuit.

There are two types of foreign material coatings which can develop on the gold-plated contacts of a plug-in module. The first type is **INORGANIC**. This type of contamination results when copper "bleeds" through the gold plating and oxidizes. The second form of contamination involves **ORGANIC** substances, which usually are a result of careless handling, and are mainly made up of fingerprints, salts, and oils deposited when the plug-in boards are handled by the gold-plated contacts. Contamination by organic substances can be greatly reduced by careful handling of the modules.

Although rack connectors are usually of the self-cleaning type, it may become necessary to clean the module fingers to ensure reliable connection. When module contacts are in need of cleaning, the following procedures are recommended:

Removal of Inorganic Contaminants

- a. Immerse contacts of plug-in board in an ultrasonic bath of deionized water and a detergent, such as Liquinix, for at least 30 seconds.
- b. Repeat step (a) with pure deionized water only.

CAUTION

REMOVE WATER IMMEDIATELY FROM CONTACTS. IF THIS IS NOT DONE QUICKLY, DAMAGE TO CONTACTS MAY RESULT.

- c. Remove water by immersing contacts in an ethane or methanol bath to same depth used during the ultrasonic cleaning of step (a). Never wipe or use an abrasive cleaner on the contacts. If wiping is necessary, use K-Dry towels or equivalent.

Removal of Organic Contaminants

- a. After inorganic contaminants and water have been removed, organic materials may be removed by immersion of contacts in trichloroethane for at least 30 seconds.

CAUTION

NEVER USE AN ERASER ON THE CONTACTS. THE USE OF ABRASIVE CLEANERS OR ERASERS ON PLUG-IN BOARD CONTACTS IS CONSIDERED A PHYSICAL ABUSE TO THE PLUG-IN UNIT AND MAY VOID THE UNIT WARRANTY.

- b. Let contacts air dry or wipe with a very fine, nonabrasive material such as K-Dry towels or equivalent.

5.3.2 Component Replacement General Information

Replace all defective components with identical parts. Refer to Section 6 for a list of recommended replacement parts. The last row of numbers in the parts list is the number of spares recommended to be kept on hand for that part, per unit, for up to ten units of the same type. For more than ten units, a spares complement of 10% on the indicated parts should be used.

5.3.3 Component Replacement Techniques

Most parts used in the unit are quite small and are located in a confined area. Therefore, small hand tools are a necessity when servicing the unit. The following is a summary of the general techniques and precautions that should be observed to prevent damage to components in the unit:

CAUTION

CMOS INTEGRATED CIRCUITS ARE VERY SUSCEPTIBLE TO STATIC ELECTRICITY. WHEN REPLACING THESE COMPONENTS, DO NOT HANDLE LEADS BEFORE SOLDERING INTO BOARD. ENSURE THAT SOLDERING IRON IS GROUNDED. SOLDER INTEGRATED CIRCUITS LEAD V (POWER INPUT) BEFORE SOLDERING G (GROUND CONNECTION). FAILURE TO TAKE THESE PRECAUTIONS WILL DAMAGE COMPONENTS.

- a. Use a transformer-operated low-voltage soldering iron with a grounded tip and rated at not more than 50 watts. A temperature-controlled tip is desirable.
- b. Use extreme care when unsoldering the leads to any component. Do not keep the soldering iron on a point for more than a few seconds at a time. Use a suction-type solder-removing tool (solder sucker) as an aid in unsoldering transistors and integrated circuits. The protective coating on the unit may be removed with trichlorethane or equivalent. Be sure adequate ventilation is provided when using this or any other chemical.

NOTE

Unused connections on integrated circuits are left unsoldered to aid in removal. Refer to the assembly drawing for more complete information.

- c. Do not excessively bend or twist the leads of small components; they break easily.
- d. Before removing a component, observe the lead dress. Be sure that the lead dress of the replacement is the same as that of the original.
- e. Handle MOSFETs only by the case; if the fingers are allowed to contact the leads, the

MOSFET may be ruined. Be sure to leave the metal sleeve around the leads until just before the device is installed on the printed circuit board.

- f. Remove all flux from soldered joints with trichlorethane or equivalent.

NOTE

Units that were calibrated at the factory to customer's specifications have protective caps over the SPAN and ZERO potentiometers. These caps must be removed so the unit can be recalibrated. LIFT, DO NOT TWIST, the caps off, using a screwdriver tip as a prying tool. Snap the caps back in place, WITHOUT TWISTING, when recalibration has been completed.

- g. Test the unit for proper operation and, if necessary, recalibrate by the procedure given in Section 2.
- h. Check that all leads are clear of the board edge before reinstalling the board into its case.
- i. When reinstalling the unit onto the mounting bracket, be sure to use the same screws (or screws of the same size) as the ones removed. Longer screws will damage the unit.

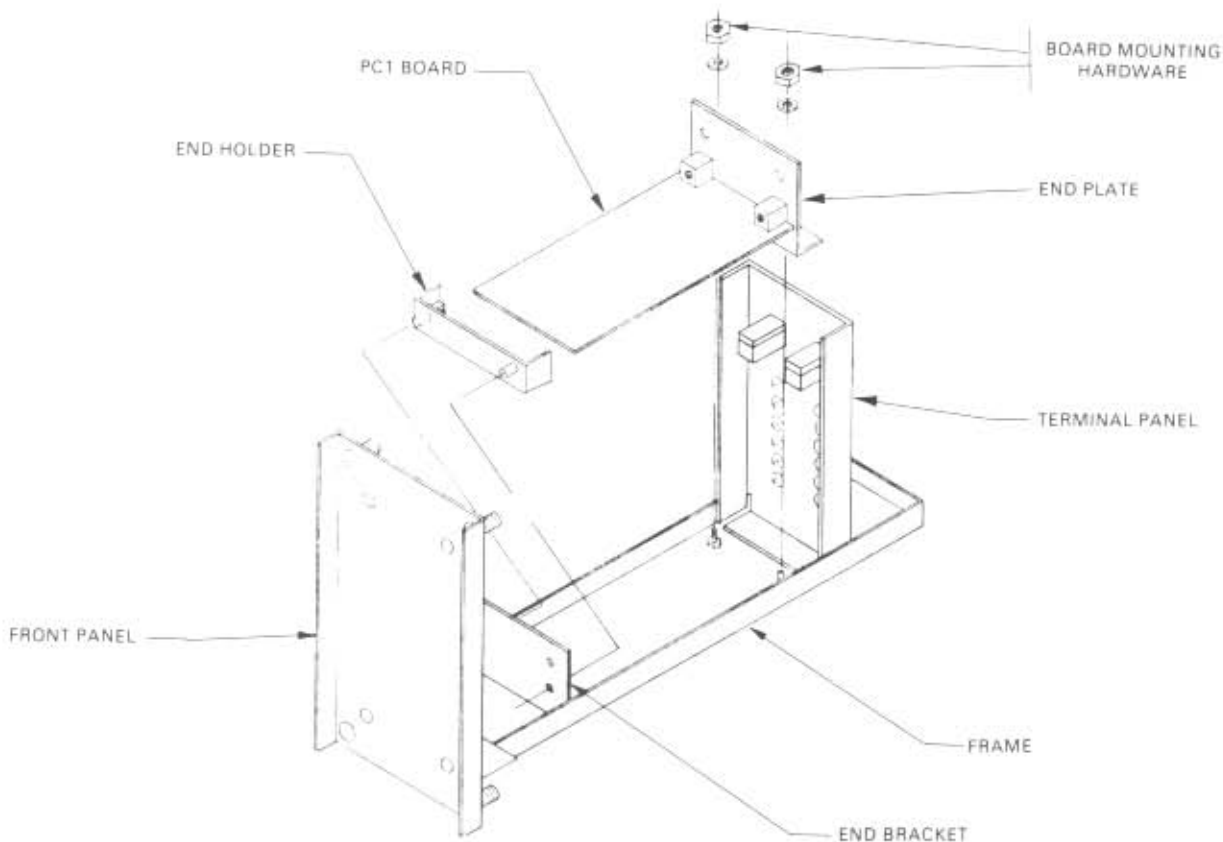

Figure 5-1. Disassembly of PM Units

TABLE 5-1. WAVE FORMS AND VOLTAGES

TEST POINT(S)	WAVE FORM AND AMPLITUDE OR VOLTAGE LEVEL
1	
2	
3	
4	
5	
6	

TEST POINT	WAVEFORM	POWER INPUT AND WAVEFORM AMPLITUDE	
		24VDC/117VAC 220VAC/240VAC	45VDC
A		48V	90V

195-701-00A
AXB MULTIPLIER MODULE

6.1 GENERAL

This section consists of a computer print-out table that provides parts identification information for the unit. Wiring lists have been provided in this section as an aid to the maintenance personnel.

Parts information is grouped according to the number of assemblies. If the unit contains two PC boards, the table will be divided into two major sections: one section will contain information related to PC1 and the other section will list PC2 components information. Each major section in the table contains a complete parts list headed LIST OF MATERIALS specifying which PC board it is describing. This list is usually found at the end of the section. The list of materials consists of the following headings:

ITEM: A reference numeral used for data processing and not used by maintenance personnel.

NAME: Gives the nomenclature of the part.

DESCRIPTION: Identifies the component by manufacturer's part number, usually followed by component's parameters or value.

REF: Lists the reference designation for the components described in Section 4 and illustrated in the schematics and assembly drawings.

PART NUMBER: This column specifies the Moore Industries assigned part number. This is the part identification required when ordering parts from Moore Industries.

SPARE: The numeral in this column specifies the recommended number of component spares per unit type that should be kept on hand by maintenance personnel.

6.2 GLOSSARY OF ABBREVIATIONS

C	Capacitor	T	Transformer
CR	Diode — Zener included	IC	Integrated circuit
HW	Special hardware	Q	Transistor
J	Connecting buss wire	LED	Light emitting diode
L	Inductor	TB	Terminal block
LB	Label	VS	Voltage regulating varistor
PC	Printed circuit board	VR	Voltage Regulator
R	Resistor		

REV.	DESCRIPTION	DATE	BY	APPROV.
U	ECO 6218	10/1/64	CO	1-1

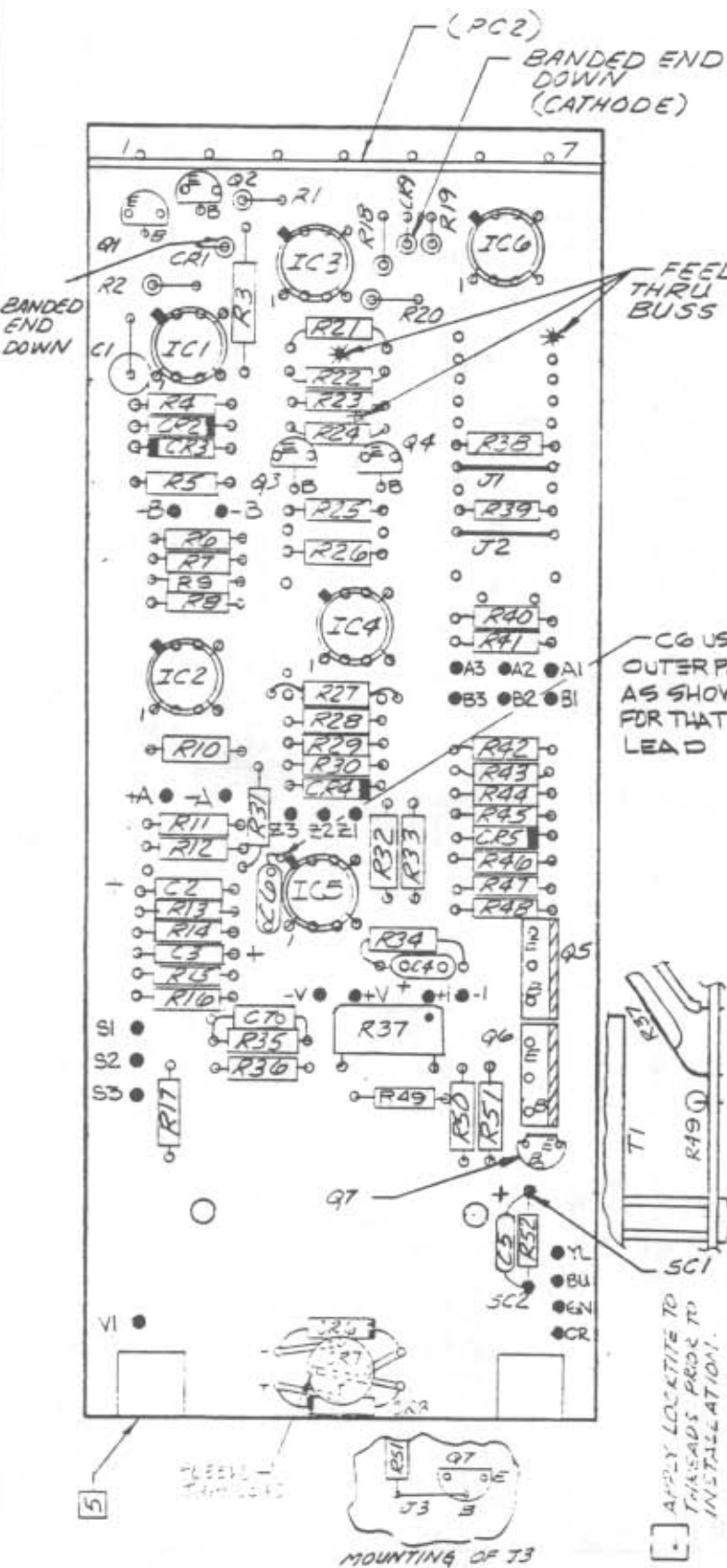

REFERENCE DESIGNATION		MANUFACTURER		PART NAME		LIST OF MATERIALS	
MOORE INDUSTRIES INC. VAN NUYS • CALIF.		P.C.B.D. ASS'Y, STANDARD AXB (PCB)		SCALE 2/1		JOB NO 195	
195-501-00 U		By Lot 2		DO NOT SCALE DRAWING			
ITEM		PART NUMBER		DRAWN		CHECK	
-1		R100		R101		R102	
TOOL UNLESS NOTED		FINISH		ON HSG			
X 1		X 1		X 1		X 1	
X 2		X 2		X 2		X 2	
X 3		X 3		X 3		X 3	
X 4		X 4		X 4		X 4	
X 5		X 5		X 5		X 5	
X 6		X 6		X 6		X 6	
X 7		X 7		X 7		X 7	
X 8		X 8		X 8		X 8	
X 9		X 9		X 9		X 9	
X 10		X 10		X 10		X 10	
X 11		X 11		X 11		X 11	
X 12		X 12		X 12		X 12	
X 13		X 13		X 13		X 13	
X 14		X 14		X 14		X 14	
X 15		X 15		X 15		X 15	
X 16		X 16		X 16		X 16	
X 17		X 17		X 17		X 17	
X 18		X 18		X 18		X 18	
X 19		X 19		X 19		X 19	
X 20		X 20		X 20		X 20	
X 21		X 21		X 21		X 21	
X 22		X 22		X 22		X 22	
X 23		X 23		X 23		X 23	
X 24		X 24		X 24		X 24	
X 25		X 25		X 25		X 25	
X 26		X 26		X 26		X 26	
X 27		X 27		X 27		X 27	
X 28		X 28		X 28		X 28	
X 29		X 29		X 29		X 29	
X 30		X 30		X 30		X 30	
X 31		X 31		X 31		X 31	
X 32		X 32		X 32		X 32	
X 33		X 33		X 33		X 33	
X 34		X 34		X 34		X 34	
X 35		X 35		X 35		X 35	
X 36		X 36		X 36		X 36	
X 37		X 37		X 37		X 37	
X 38		X 38		X 38		X 38	
X 39		X 39		X 39		X 39	
X 40		X 40		X 40		X 40	
X 41		X 41		X 41		X 41	
X 42		X 42		X 42		X 42	
X 43		X 43		X 43		X 43	
X 44		X 44		X 44		X 44	
X 45		X 45		X 45		X 45	
X 46		X 46		X 46		X 46	
X 47		X 47		X 47		X 47	
X 48		X 48		X 48		X 48	
X 49		X 49		X 49		X 49	
X 50		X 50		X 50		X 50	
X 51		X 51		X 51		X 51	
X 52		X 52		X 52		X 52	
X 53		X 53		X 53		X 53	
X 54		X 54		X 54		X 54	
X 55		X 55		X 55		X 55	
X 56		X 56		X 56		X 56	
X 57		X 57		X 57		X 57	
X 58		X 58		X 58		X 58	
X 59		X 59		X 59		X 59	
X 60		X 60		X 60		X 60	
X 61		X 61		X 61		X 61	
X 62		X 62		X 62		X 62	
X 63		X 63		X 63		X 63	
X 64		X 64		X 64		X 64	
X 65		X 65		X 65		X 65	
X 66		X 66		X 66		X 66	
X 67		X 67		X 67		X 67	
X 68		X 68		X 68		X 68	
X 69		X 69		X 69		X 69	
X 70		X 70		X 70		X 70	
X 71		X 71		X 71		X 71	
X 72		X 72		X 72		X 72	
X 73		X 73		X 73		X 73	
X 74		X 74		X 74		X 74	
X 75		X 75		X 75		X 75	
X 76		X 76		X 76		X 76	
X 77		X 77		X 77		X 77	
X 78		X 78		X 78		X 78	
X 79		X 79		X 79		X 79	
X 80		X 80		X 80		X 80	
X 81		X 81		X 81		X 81	
X 82		X 82		X 82		X 82	
X 83		X 83		X 83		X 83	
X 84		X 84		X 84		X 84	
X 85		X 85		X 85		X 85	
X 86		X 86		X 86		X 86	
X 87		X 87		X 87		X 87	
X 88		X 88		X 88		X 88	
X 89		X 89		X 89		X 89	
X 90		X 90		X 90		X 90	
X 91		X 91		X 91		X 91	
X 92		X 92		X 92		X 92	
X 93		X 93		X 93		X 93	
X 94		X 94		X 94		X 94	
X 95		X 95		X 95		X 95	
X 96		X 96		X 96		X 96	
X 97		X 97		X 97		X 97	
X 98		X 98		X 98		X 98	
X 99		X 99		X 99		X 99	
X 100		X 100		X 100		X 100	

- 1. ALL JUMPERS 22 AWG BUSS, TEFLON SLEEVED AS REQ'D.
- 2. ALL LEADS AND TERMINALS MUST BE SOLDERED TO PADS.
- 3. INDICATES METAL SIDE OF Q5 & Q6.
- 4. INSTALL A-ZERO & B-ZERO POTS ON FRONT PANEL UP-SIDE DOWN TO CLEAR T1.
- 5. FOR MOUNTING OF SWAGE BLOCKS SEE CASE ASSEMBLY LISTED ON TRAVELLER.
- 6. APPLY LOCATE TO THIS SIDE OF PCB TO INSTALLATION.

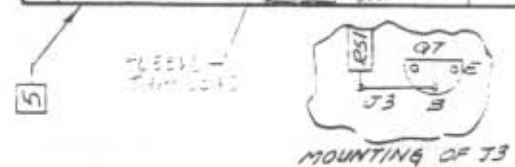

NOTES: UNLESS OTHERWISE SPECIFIED

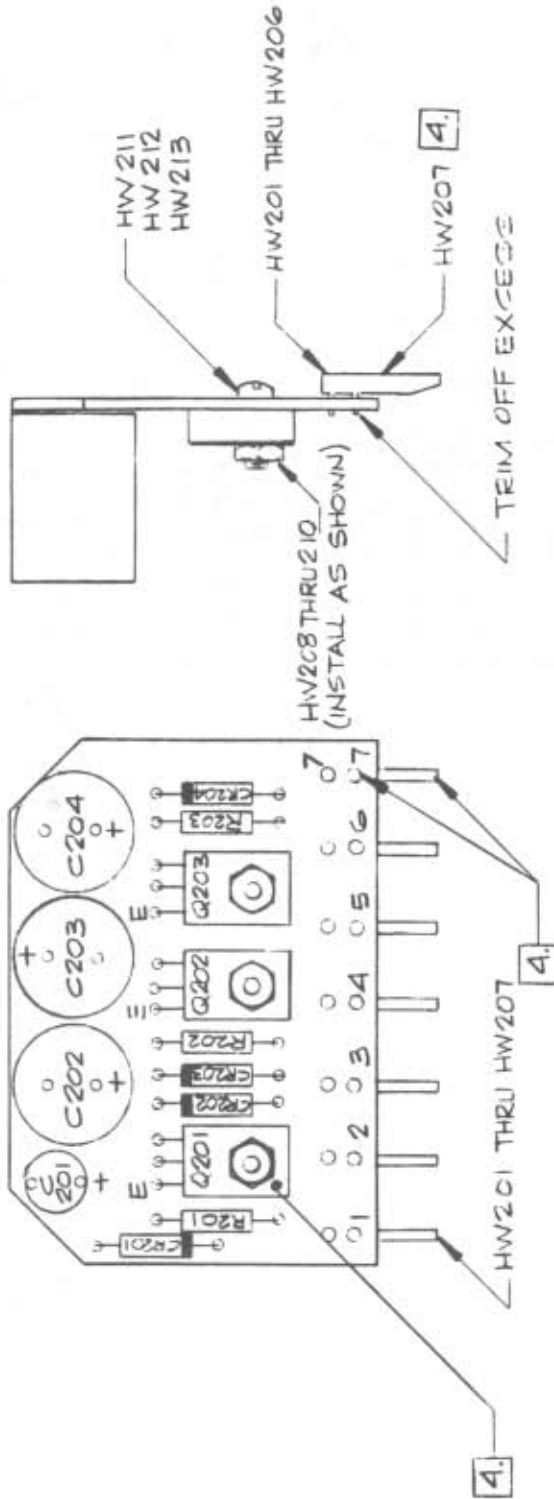

4. CUT HW207 BETWEEN TWO SOLDER PINS & REMOVE UPPER PORTION PRIOR TO INSERTING & SOLDERING IN BOTTOM HOLE. KEEP TOP HOLE FREE OF SOLDER.
 3. FOR SCHEMATIC SEE DRAWING 195-401-00.
 2. METAL SIDE OF Q201, Q202 & Q203 TO FACE UP; (AWAY FROM BOARD).
 1. ALL LEADS MUST BE SOLDERED TO PADS
- NOTES: UNLESS OTHERWISE SPECIFIED

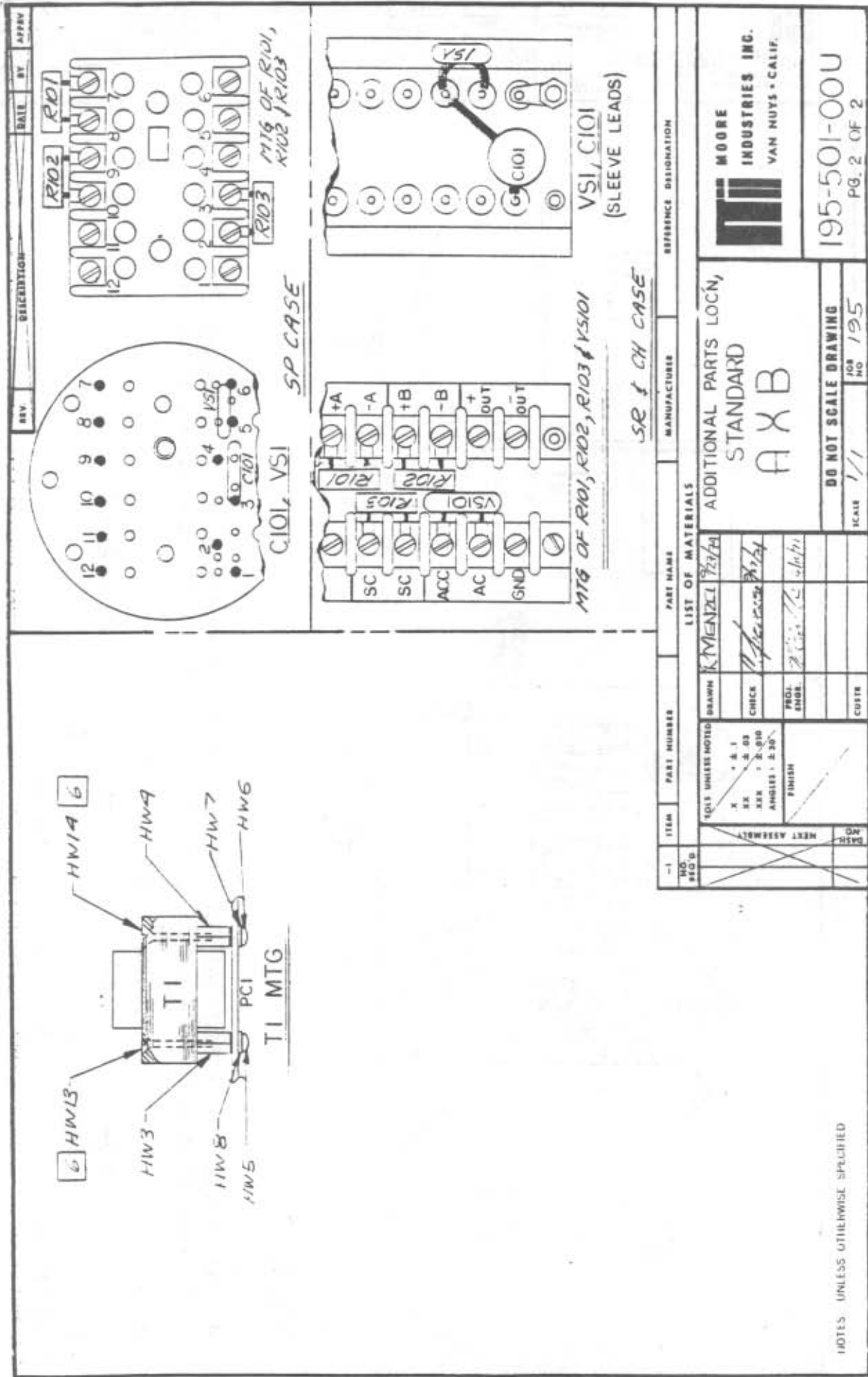

REV.	DESCRIPTION	DATE	BY	APPROV.
------	-------------	------	----	---------

MTG OF R101, R102, R103
 SP CASE
 C101, V51
 V51, C101
 (SLEEVE LEADS)
 SR & CH CASE

ITEM NO.	ITEM	PART NUMBER	PART NAME	MANUFACTURER	REFERENCE DESIGNATION
----------	------	-------------	-----------	--------------	-----------------------

LIST OF MATERIALS					
NO. UNLESS NOTED	DRAWN	BY	DATE	ADDITIONAL PARTS LOCN, STANDARD	
1	K. MENZEL	7/27/74		A X B	
2	CHECK			DO NOT SCALE DRAWING	
3	PROJ. ENGR.			SCALE	1/1
4	COSTR.			HOS. NO.	195

MOORE INDUSTRIES INC.
 VAN NUYS - CALIF.
 195-501-00U
 PG. 2 OF 2

NOTES - UNLESS OTHERWISE SPECIFIED

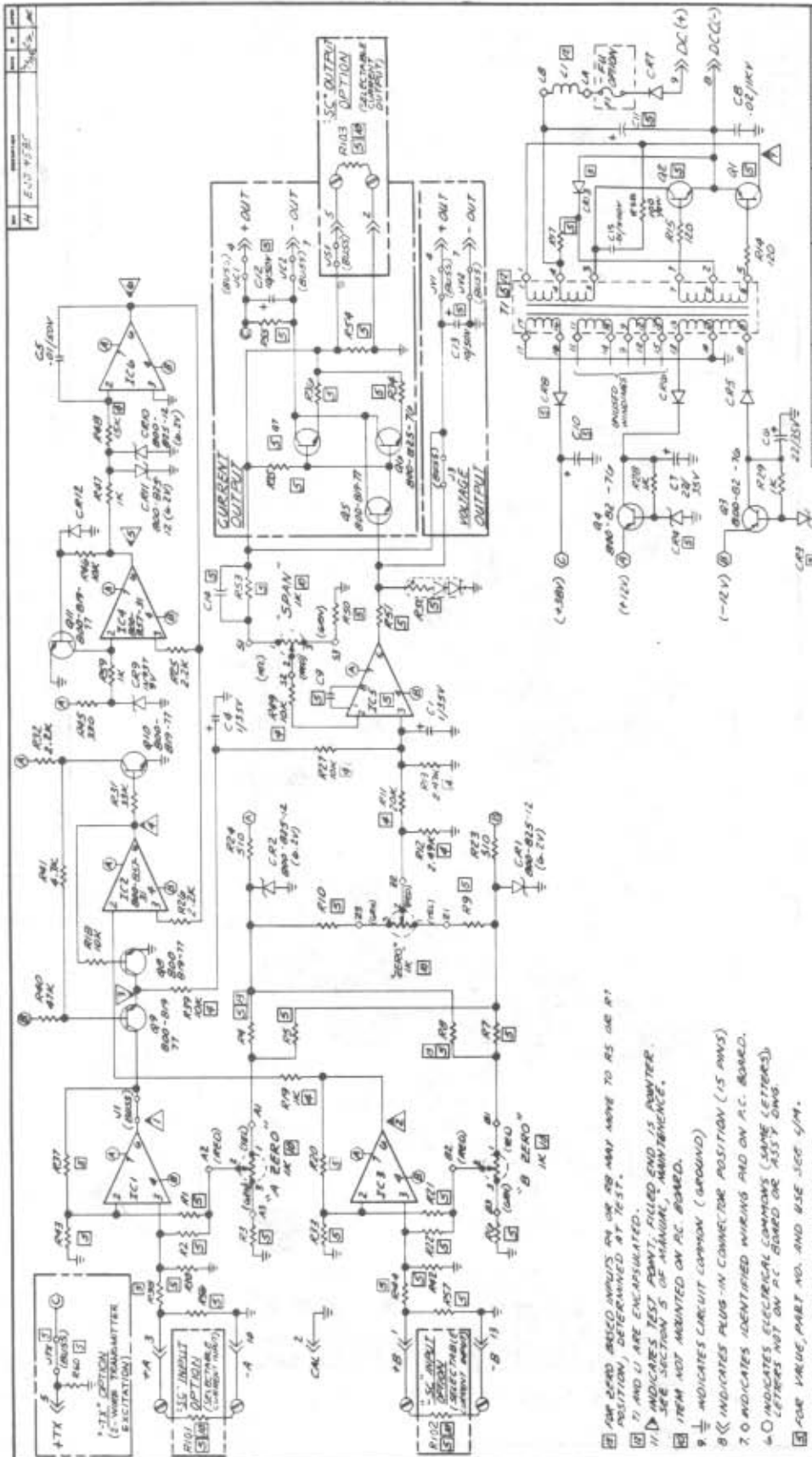

NO.	DESCRIPTION	QTY.	REMARKS
1	RESISTOR 100 OHM	1	
2	RESISTOR 100 OHM	1	
3	RESISTOR 100 OHM	1	
4	RESISTOR 100 OHM	1	
5	RESISTOR 100 OHM	1	
6	RESISTOR 100 OHM	1	
7	RESISTOR 100 OHM	1	
8	RESISTOR 100 OHM	1	
9	RESISTOR 100 OHM	1	
10	RESISTOR 100 OHM	1	
11	RESISTOR 100 OHM	1	
12	RESISTOR 100 OHM	1	
13	RESISTOR 100 OHM	1	
14	RESISTOR 100 OHM	1	
15	RESISTOR 100 OHM	1	
16	RESISTOR 100 OHM	1	
17	RESISTOR 100 OHM	1	
18	RESISTOR 100 OHM	1	
19	RESISTOR 100 OHM	1	
20	RESISTOR 100 OHM	1	
21	RESISTOR 100 OHM	1	
22	RESISTOR 100 OHM	1	
23	RESISTOR 100 OHM	1	
24	RESISTOR 100 OHM	1	
25	RESISTOR 100 OHM	1	
26	RESISTOR 100 OHM	1	
27	RESISTOR 100 OHM	1	
28	RESISTOR 100 OHM	1	
29	RESISTOR 100 OHM	1	
30	RESISTOR 100 OHM	1	
31	RESISTOR 100 OHM	1	
32	RESISTOR 100 OHM	1	
33	RESISTOR 100 OHM	1	
34	RESISTOR 100 OHM	1	
35	RESISTOR 100 OHM	1	
36	RESISTOR 100 OHM	1	
37	RESISTOR 100 OHM	1	
38	RESISTOR 100 OHM	1	
39	RESISTOR 100 OHM	1	
40	RESISTOR 100 OHM	1	
41	RESISTOR 100 OHM	1	
42	RESISTOR 100 OHM	1	
43	RESISTOR 100 OHM	1	
44	RESISTOR 100 OHM	1	
45	RESISTOR 100 OHM	1	
46	RESISTOR 100 OHM	1	
47	RESISTOR 100 OHM	1	
48	RESISTOR 100 OHM	1	
49	RESISTOR 100 OHM	1	
50	RESISTOR 100 OHM	1	
51	RESISTOR 100 OHM	1	
52	RESISTOR 100 OHM	1	
53	RESISTOR 100 OHM	1	
54	RESISTOR 100 OHM	1	
55	RESISTOR 100 OHM	1	
56	RESISTOR 100 OHM	1	
57	RESISTOR 100 OHM	1	
58	RESISTOR 100 OHM	1	
59	RESISTOR 100 OHM	1	
60	RESISTOR 100 OHM	1	
61	RESISTOR 100 OHM	1	
62	RESISTOR 100 OHM	1	
63	RESISTOR 100 OHM	1	
64	RESISTOR 100 OHM	1	
65	RESISTOR 100 OHM	1	
66	RESISTOR 100 OHM	1	
67	RESISTOR 100 OHM	1	
68	RESISTOR 100 OHM	1	
69	RESISTOR 100 OHM	1	
70	RESISTOR 100 OHM	1	
71	RESISTOR 100 OHM	1	
72	RESISTOR 100 OHM	1	
73	RESISTOR 100 OHM	1	
74	RESISTOR 100 OHM	1	
75	RESISTOR 100 OHM	1	
76	RESISTOR 100 OHM	1	
77	RESISTOR 100 OHM	1	
78	RESISTOR 100 OHM	1	
79	RESISTOR 100 OHM	1	
80	RESISTOR 100 OHM	1	
81	RESISTOR 100 OHM	1	
82	RESISTOR 100 OHM	1	
83	RESISTOR 100 OHM	1	
84	RESISTOR 100 OHM	1	
85	RESISTOR 100 OHM	1	
86	RESISTOR 100 OHM	1	
87	RESISTOR 100 OHM	1	
88	RESISTOR 100 OHM	1	
89	RESISTOR 100 OHM	1	
90	RESISTOR 100 OHM	1	
91	RESISTOR 100 OHM	1	
92	RESISTOR 100 OHM	1	
93	RESISTOR 100 OHM	1	
94	RESISTOR 100 OHM	1	
95	RESISTOR 100 OHM	1	
96	RESISTOR 100 OHM	1	
97	RESISTOR 100 OHM	1	
98	RESISTOR 100 OHM	1	
99	RESISTOR 100 OHM	1	
100	RESISTOR 100 OHM	1	

- FOR ZERO BRIDGE INPUTS IN OR RB MAY HAVE TO RS OR R1 POSITION, DETERMINED BY TEST.
- R1 AND U1 ARE ENCASCATED.
- INDICATES TEST POINT, FILLED END IS ADJUSTER. SEE SECTION 5 OF MANUAL MAINTENANCE.
- ITEM NOT MOUNTED ON PC BOARD.
- INDICATES CIRCUIT COMMON (GROUND).
- INDICATES PLUS-IN CONNECTOR POSITION (IS ANNS).
- INDICATES IDENTIFIED WIRING AND ON PC BOARD.
- INDICATES ELECTRICAL COMMONS (SAME LETTERS) LETTERS NOT ON PC BOARD OR ASSY DWG.
- FOR VALUE, PART NO. AND USE IEC 609.
- METAL FILM RESISTOR (ANALOG) 1/4W.
- ALL ADJUSTMENT METERS INCREASE C.N. FROM 1 TO 5.
- ALL METERS GETS ARE ALL 1/4W AND 0.5% TOL; DIALS ARE 000-4140-11 AND RESISTORS ARE CBB COMP, 1/4W-1% DWG.
- ALL RESISTANCE ARE IN OHMS, ALL CAPACITANCE VALUES ARE IN MICROFARADS.

195-451-00 H

SCHEMATIC
PLUS-IN
AXB

REVISIONS

NO.	DATE	DESCRIPTION
1		
2		
3		
4		
5		
6		
7		
8		
9		
10		

REVISIONS

195-551-00
PLUG-IN AXB, ASSY *PCI*

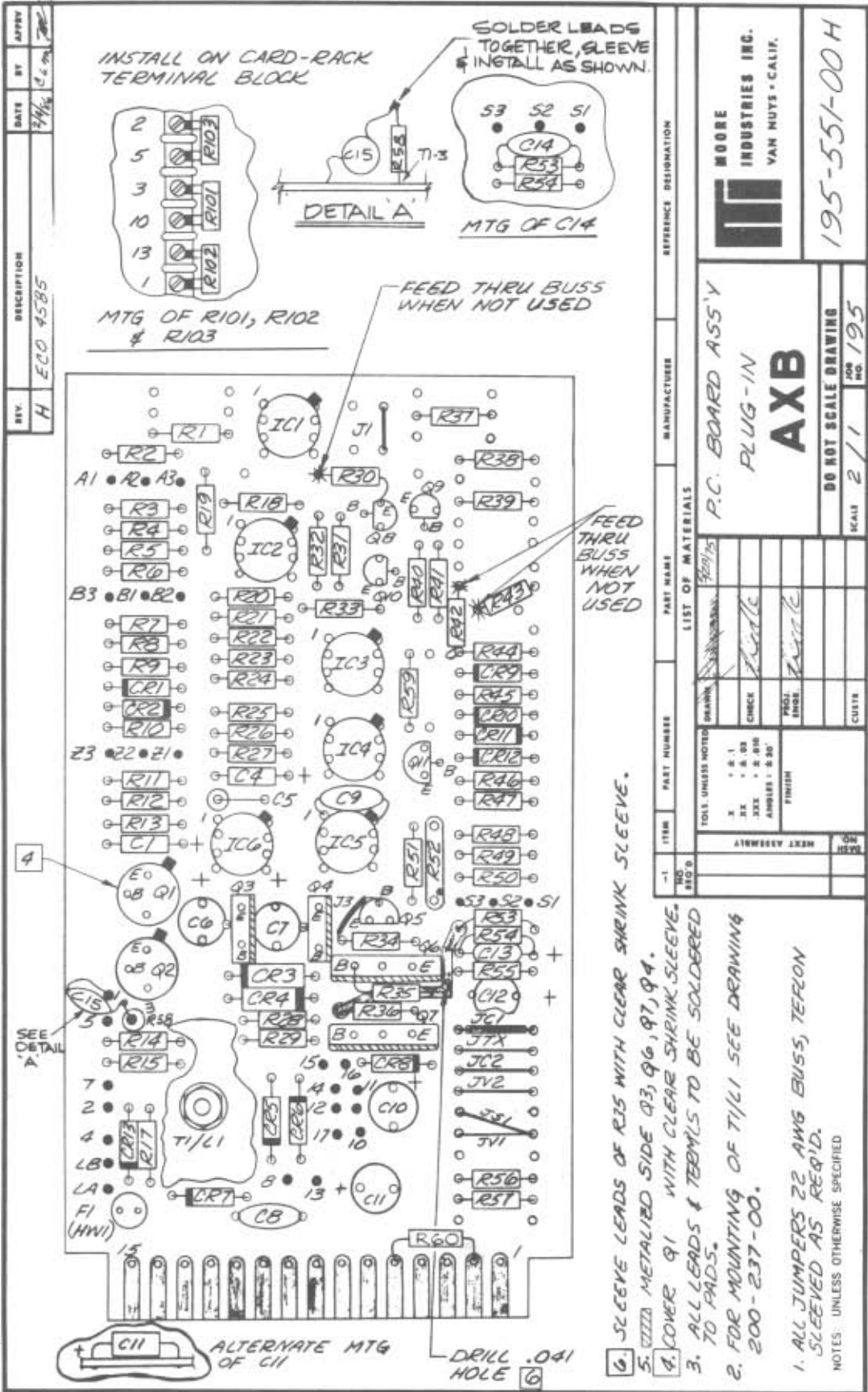

REV. H		DATE 3/4/75		BY C. M.		APPROV. [Signature]	
DESCRIPTION H ECO 4585							
PART NAME P.C. BOARD ASS'Y PLUG-IN AXB				MANUFACTURER MOORE INDUSTRIES INC. VAN NUYS - CALIF.			
LIST OF MATERIALS				REFERENCE DESIGNATION 195-551-00 H			
ITEM NO. 195-003		PART NUMBER		DRAWN		CHECK	
TOLERANCES UNLESS NOTED		FINISH		PROG. INCH		CUTTE	
.001		.001		.001		.001	
.002		.002		.002		.002	
.005		.005		.005		.005	
.010		.010		.010		.010	
.020		.020		.020		.020	
.030		.030		.030		.030	
.040		.040		.040		.040	
.050		.050		.050		.050	
.060		.060		.060		.060	
.070		.070		.070		.070	
.080		.080		.080		.080	
.090		.090		.090		.090	
.100		.100		.100		.100	
.120		.120		.120		.120	
.150		.150		.150		.150	
.200		.200		.200		.200	
.250		.250		.250		.250	
.300		.300		.300		.300	
.375		.375		.375		.375	
.500		.500		.500		.500	
.625		.625		.625		.625	
.750		.750		.750		.750	
1.000		1.000		1.000		1.000	
1.250		1.250		1.250		1.250	
1.500		1.500		1.500		1.500	
1.750		1.750		1.750		1.750	
2.000		2.000		2.000		2.000	
2.500		2.500		2.500		2.500	
3.000		3.000		3.000		3.000	
3.750		3.750		3.750		3.750	
4.500		4.500		4.500		4.500	
5.000		5.000		5.000		5.000	
6.000		6.000		6.000		6.000	
7.000		7.000		7.000		7.000	
8.000		8.000		8.000		8.000	
9.000		9.000		9.000		9.000	
10.000		10.000		10.000		10.000	
12.000		12.000		12.000		12.000	
15.000		15.000		15.000		15.000	
20.000		20.000		20.000		20.000	
25.000		25.000		25.000		25.000	
30.000		30.000		30.000		30.000	
37.500		37.500		37.500		37.500	
45.000		45.000		45.000		45.000	
50.000		50.000		50.000		50.000	
60.000		60.000		60.000		60.000	
75.000		75.000		75.000		75.000	
90.000		90.000		90.000		90.000	
100.000		100.000		100.000		100.000	
120.000		120.000		120.000		120.000	
150.000		150.000		150.000		150.000	
200.000		200.000		200.000		200.000	
250.000		250.000		250.000		250.000	
300.000		300.000		300.000		300.000	
375.000		375.000		375.000		375.000	
450.000		450.000		450.000		450.000	
500.000		500.000		500.000		500.000	
600.000		600.000		600.000		600.000	
750.000		750.000		750.000		750.000	
900.000		900.000		900.000		900.000	
1000.000		1000.000		1000.000		1000.000	

1. ALL JUMPERS 22 AWG BUSS, TEFロン SLEEVED AS REQ'D.
2. FOR MOUNTING OF T1/L1 SEE DRAWING 200-237-00.
3. ALL LEADS & TEBYLS TO BE SOLDERED TO PADS.
4. COVER Q1 WITH CLEAR SHRINK SLEEVE.
5. SOLDER METALIZED SIDE Q3, Q6, Q7, Q4.
6. SLEEVE LEADS OF R15 WITH CLEAR SHRINK SLEEVE.

NOTES: UNLESS OTHERWISE SPECIFIED



Declaration of Conformity

EMC Directive 89/336/EEC



Manufacturer's Name: Moore Industries-International, Inc.
Manufacturer's Address: 16650 Schoenborn Street
 North Hills, CA 91343-6196
 USA

Declares that the product(s):

Product Name: AXB

	<u>MODEL</u>	<u>INPUT</u>	<u>OUTPUT</u>	<u>POWER</u>	<u>OPTIONS</u>	<u>HOUSING</u>
Model Number(s):	AXB	4-20 or 10-50mA	4-20 or 10-50mA	117VAC	* -CE ¹	**
	AXB	4-20 or 10-50mA	4-20 or 10-50mA	24VDC	* -CE ¹	**

*Indicates any option/s as stated in the product data sheet.
 **Indicates any housing excluding plug-ins and panel mount.

Conforms to the following EMC specifications:

- EN50081-1, 1992, Generic Emissions Standard, Residential, Commercial and Light Industry.
- EN50082-1, 1992, Generic Immunity Standard, Residential, Commercial and Light Industry.
- EN61010-1, 1995, Safety requirements for electrical equipment for measurement and control use.

Supplemental Information:

¹ RF filters are required for the -CE option.

November 23, 1998

 Date

Fred Adt
 Quality Assurance Director

Robert Stockham
 Moore Industries-International, Inc.

European Contact: Your Local Moore Industries Sales and Service Office

The Interface Solution Experts • www.miinet.com



United States • info@miinet.com
 Tel: (818) 894-7111 • FAX: (818) 891-2816
 Australia • sales@mooreind.com.au
 Tel: (02) 8536-7200 • FAX: (02) 9525-7296

Belgium • info@mooreind.be
 Tel: 03/448.10.18 • FAX: 03/440.17.97
 The Netherlands • sales@mooreind.nl
 Tel: (0)344-617971 • FAX: (0)344-615920

China • sales@mooreind.sh.cn
 Tel: 86-21-62481120 • FAX: 86-21-62490635
 United Kingdom • sales@mooreind.com
 Tel: 01293 514488 • FAX: 01293 536852

RETURN PROCEDURES

To return equipment to Moore Industries for repair, follow these four steps:

1. Call Moore Industries and request a Returned Material Authorization (RMA) number.

Warranty Repair –

If you are unsure if your unit is still under warranty, we can use the unit's serial number to verify the warranty status for you over the phone. Be sure to include the RMA number on all documentation.

Non-Warranty Repair –

If your unit is out of warranty, be prepared to give us a Purchase Order number when you call. In most cases, we will be able to quote you the repair costs at that time. The repair price you are quoted will be a "Not To Exceed" price, which means that the actual repair costs may be less than the quote. Be sure to include the RMA number on all documentation.

2. Provide us with the following documentation:
 - a) A note listing the symptoms that indicate the unit needs repair
 - b) Complete shipping information for return of the equipment after repair
 - c) The name and phone number of the person to contact if questions arise at the factory
3. Use sufficient packing material and carefully pack the equipment in a sturdy shipping container.
4. Ship the equipment to the Moore Industries location nearest you.

The returned equipment will be inspected and tested at the factory. A Moore Industries representative will contact the person designated on your documentation if more information is needed. The repaired equipment, or its replacement, will be returned to you in accordance with the shipping instructions furnished in your documentation.

WARRANTY DISCLAIMER

THE COMPANY MAKES NO EXPRESS, IMPLIED OR STATUTORY WARRANTIES (INCLUDING ANY WARRANTY OF MERCHANTABILITY OR OF FITNESS FOR A PARTICULAR PURPOSE) WITH RESPECT TO ANY GOODS OR SERVICES SOLD BY THE COMPANY. THE COMPANY DISCLAIMS ALL WARRANTIES ARISING FROM ANY COURSE OF DEALING OR TRADE USAGE, AND ANY BUYER OF GOODS OR SERVICES FROM THE COMPANY ACKNOWLEDGES THAT THERE ARE NO WARRANTIES IMPLIED BY CUSTOM OR USAGE IN THE TRADE OF THE BUYER AND OF THE COMPANY, AND THAT ANY PRIOR DEALINGS OF THE BUYER WITH THE COMPANY DO NOT IMPLY THAT THE COMPANY WARRANTS THE GOODS OR SERVICES IN ANY WAY.

ANY BUYER OF GOODS OR SERVICES FROM THE COMPANY AGREES WITH THE COMPANY THAT THE SOLE AND EXCLUSIVE REMEDIES FOR BREACH OF ANY WARRANTY CONCERNING THE GOODS OR SERVICES SHALL BE FOR THE COMPANY, AT ITS OPTION, TO REPAIR OR REPLACE THE GOODS OR SERVICES OR REFUND THE PURCHASE PRICE. THE COMPANY SHALL IN NO EVENT BE LIABLE FOR ANY CONSEQUENTIAL OR INCIDENTAL DAMAGES EVEN IF THE COMPANY FAILS IN ANY ATTEMPT TO REMEDY DEFECTS IN THE GOODS OR SERVICES. BUT IN SUCH CASE THE BUYER SHALL BE ENTITLED TO NO MORE THAN A REFUND OF ALL MONIES PAID TO THE COMPANY BY THE BUYER FOR PURCHASE OF THE GOODS OR SERVICES.

ANY CAUSE OF ACTION FOR BREACH OF ANY WARRANTY BY THE COMPANY SHALL BE BARRED UNLESS THE COMPANY RECEIVES FROM THE BUYER A WRITTEN NOTICE OF THE ALLEGED DEFECT OR BREACH WITHIN TEN DAYS FROM THE EARLIEST DATE ON WHICH THE BUYER COULD REASONABLY HAVE DISCOVERED THE ALLEGED DEFECT OR BREACH, AND NO ACTION FOR THE BREACH OF ANY WARRANTY SHALL BE COMMENCED BY THE BUYER ANY LATER THAN TWELVE MONTHS FROM THE EARLIEST DATE ON WHICH THE BUYER COULD REASONABLY HAVE DISCOVERED THE ALLEGED DEFECT OR BREACH.

RETURN POLICY

For a period of thirty-six (36) months from the date of shipment, and under normal conditions of use and service, Moore Industries ("The Company") will at its option replace, repair or refund the purchase price for any of its manufactured products found, upon return to the Company (transportation charges prepaid and otherwise in accordance with the return procedures established by The Company), to be defective in material or workmanship. This policy extends to the original Buyer only and not to Buyer's customers or the users of Buyer's products, unless Buyer is an engineering contractor in which case the policy shall extend to Buyer's immediate customer only. This policy shall not apply if the product has been subject to alteration, misuse, accident, neglect or improper application, installation, or operation. THE COMPANY SHALL IN NO EVENT BE LIABLE FOR ANY INCIDENTAL OR CONSEQUENTIAL DAMAGES.



WORLDWIDE • www.miinet.com

United States • info@miinet.com Tel: (818) 894-7111 • FAX: (818) 891-2816	Belgium • info@mooreind.be Tel: 03/448.10.18 • FAX: 03/440.17.97	China • sales@mooreind.sh.cn Tel: 86-21-62491499 • FAX: 86-21-62490635
Australia • sales@mooreind.com.au Tel: (02) 8536-7200 • FAX: (02) 9525-7296	The Netherlands • sales@mooreind.nl Tel: (0)344-617971 • FAX: (0)344-615920	United Kingdom • sales@mooreind.com Tel: 01293 514488 • FAX: 01293 536852